

- 1 ZINC PER QQ-Z-363.
- 2 POLYMETHYLPENTENE PER ASTM-D-1238.
- 3 PHOSPHOR BRONZE PER QQ-B-750.
- 4 BRASS PER ASTM-B-453.
- 5 BRASS PER ASTM-B-16.
- 6 NICKEL PLATE PER QQ-N-290, 3.81 μm [.000150] MINIMUM THICK.
- 7 TIN PLATE PER ASTM-B-545, 3.81 μm [.000150] MINIMUM THICK.
- 8 GOLD PLATE PER MIL-G-45204, 1.27 μm [.000050] MINIMUM THICK.
- 9 GOLD PLATE PER MIL-G-45204, 0.76 μm [.000030] MINIMUM THICK.
- 10. SEE INSTRUCTION SHEET 408-2769.

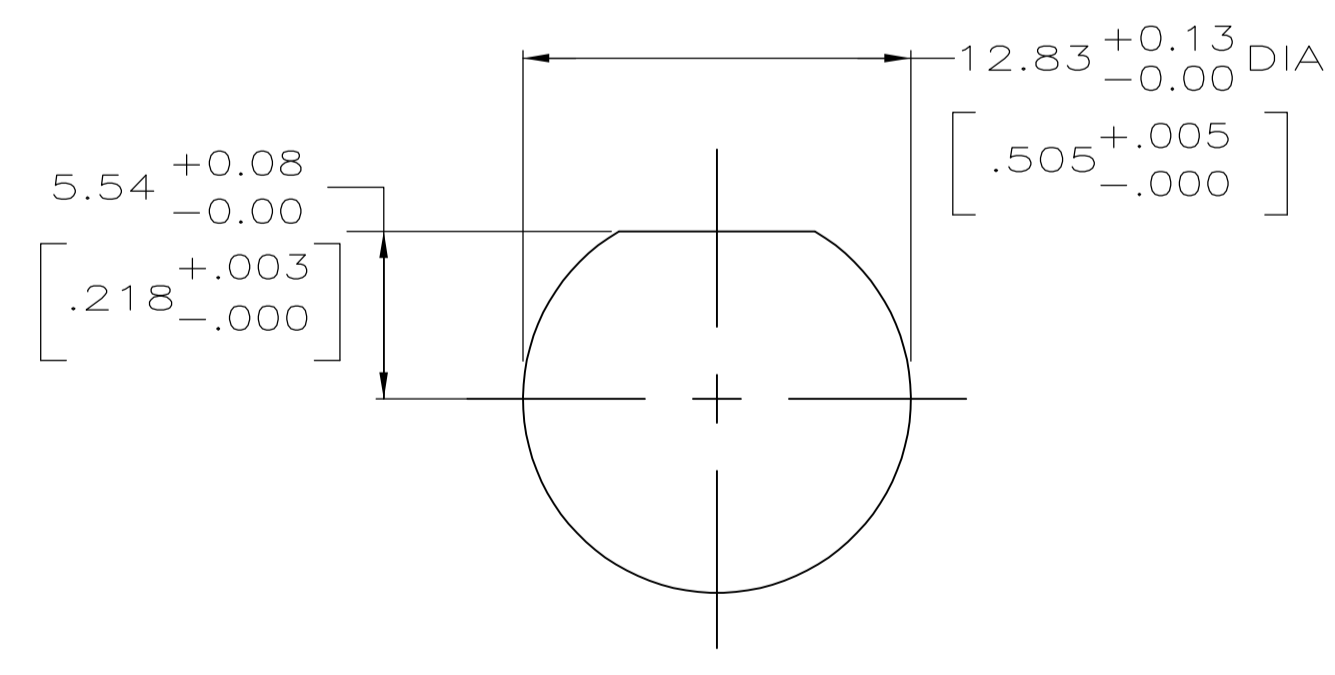

RECOMMENDED PANEL CUTOUT

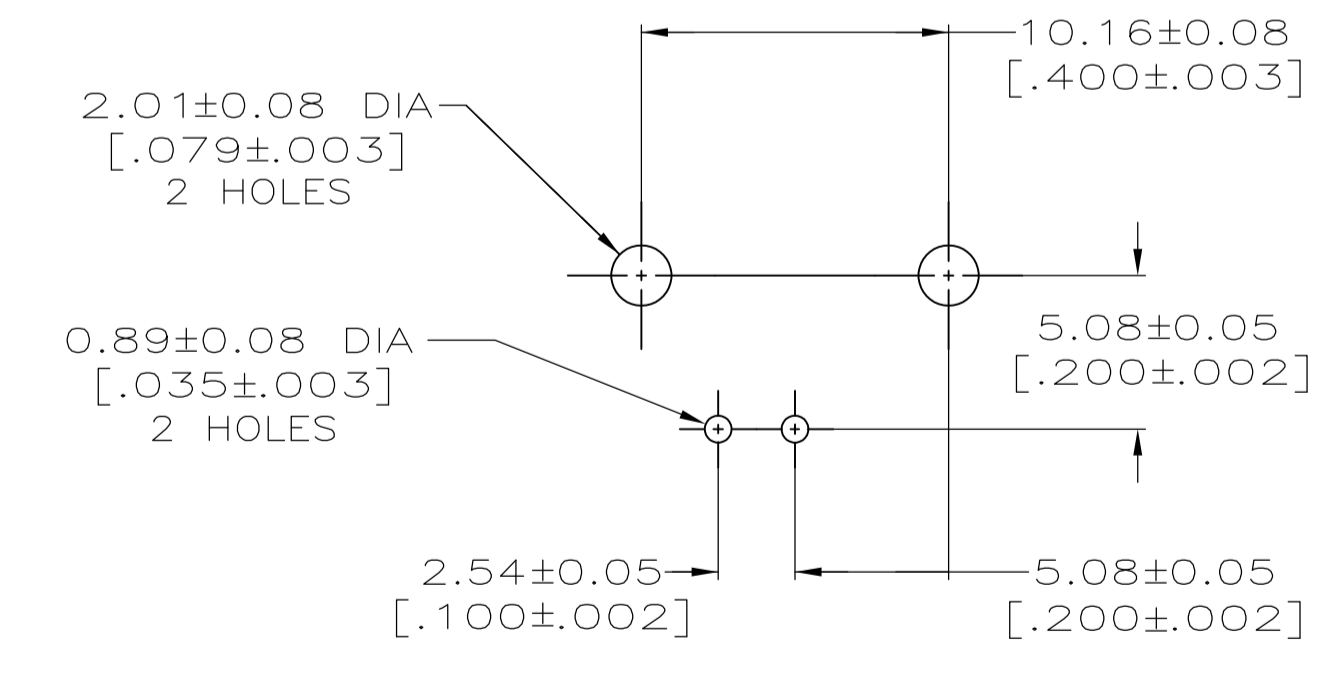

PCB CONFIGURATION

	5413879-2
	5413879-1
CONTACT FINISH	PART NUMBER

THIS DRAWING IS A CONTROLLED DOCUMENT.		DIN	22APR2005	
DIMENSIONS: mm [INCHES]		APVD	22APR2005	
TOLERANCES UNLESS OTHERWISE SPECIFIED:		NAME	JACK, RIGHT ANGLE, PCB 50 OHM, SERIES BNC	
0 PLC ± -	1 PLC ± -	APVD	22APR2005	
2 PLC ± 0.20 [.008]	3 PLC ± -	NAME	JACK, RIGHT ANGLE, PCB 50 OHM, SERIES BNC	
4 PLC ± -	ANGLES ± -	PRODUCT SPEC	108-12078	
MATERIAL SEE NOTES 1-5	FINISH SEE NOTES 6-9	APPLICATION SPEC	-	
WEIGHT		SIZE	CAGE CODE	DRAWING NO
-		A1	00779	5413879
CUSTOMER DRAWING		SCALE	4:1	SHEET 1 OF 1
		REV	A1	