

MOUNTING PAD LAYOUT REQUIRED FOR (2) 'AAAA' CLIPS

THIS DOCUMENT IS THE PROPERTY OF KEYSTONE ELECTRONICS CORP. AND SHALL NOT BE REPRODUCED, DISTRIBUTED OR USED AS A BASIS FOR MANUFACTURE WITHOUT PRIOR WRITTEN PERMISSION FROM KEYSTONE ELECTRONICS CORP.

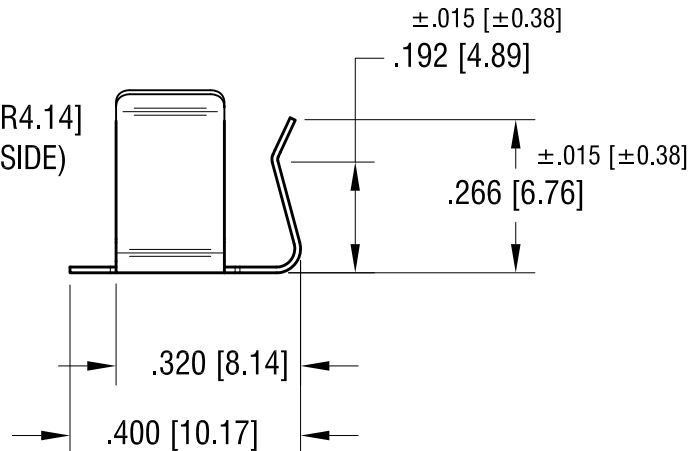
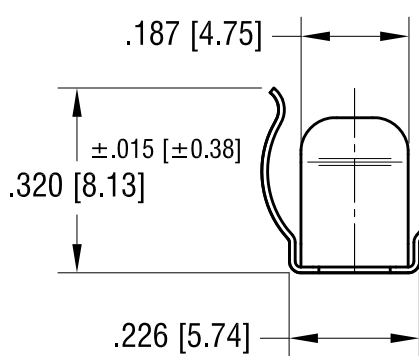
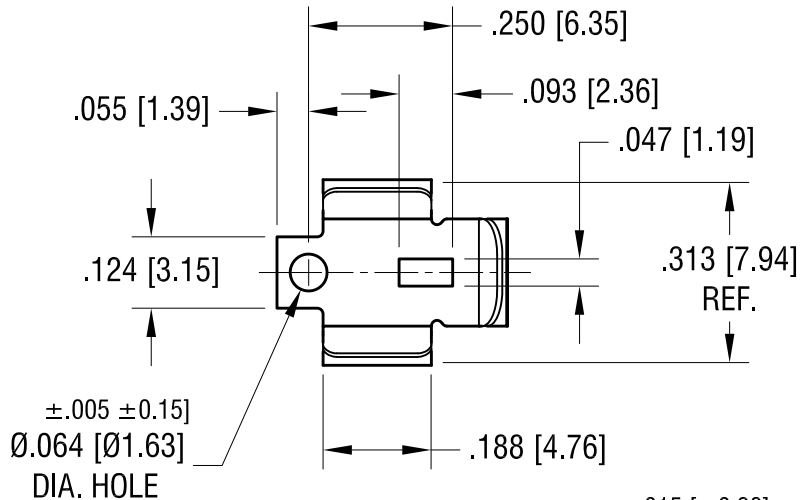
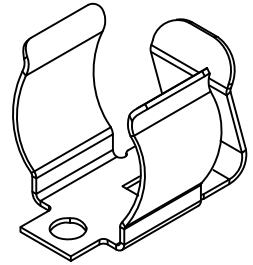
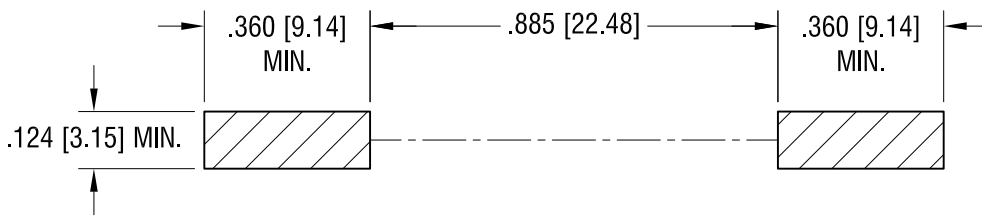

NOTE:

1. HEAT TREAT TO SPRING TEMPER

KEYSTONE ELECTRONICS CORP.

www.keyelco.com • ASTORIA, N.Y. 11105-2017 • Tel (718) 956-8900

PART NAME

'AAAA' SMT BATTERY CLIP

MATERIAL

.010 [0.25] TH'K ANNEALED SPRING STEEL

FINISH

MATTE TIN PLATE

DRN BY

NT

DATE

7.20.09

APP'D

LN

SCALE

3X

TOLERANCES

INCH [MM]

DECIMAL ±.010 [±0.25]

ANGULAR ± 1°
UNLESS OTHERWISE SPECIFIED

CODE

C

DWG NO.

550

DATE

DESCRIPTION

REV.