

Customer : AEE DISTRIBUTOR

No. KK-98-2838

Attention:

Date: Jun. 25, 1998

Your ref. No:

Your Part. No: STEC12E06

# SPECIFICATIONS

ALPS :

MODEL EC12E24242

Spec. No. :

Sample No. : G2960426M

RECEIPT STATUS

RECEIVED

By. Date

Signature

Name

Title

ALPS ELECTRIC CO., LTD.

HEAD OFFICE  
1-7, YUKIGAYA-OHTSUKA-CHO,  
OHTA-KU, TOKYO 145-8501 JAPAN

DSG'D H. Miura

APP'D Y. Kanagaki

Sales

## SPECIFICATIONS

1. THIS SPECIFICATIONS APPLY TO EC12E24242 ROTARY ENCODERS.

2. CONTENTS OF THIS SPECIFICATIONS.

4LE2124-5  
LE21240A

3. MARKING

·MARKING ON ALL UNITS  
DATE CODE

1. 一般事項 General

1-1 適用範囲 Scope

この仕様書は主として電子機器に用いる微小電流回路用12形薄形ロータリーエンコーダに適用する。  
This specification applies to 12mm size low-profile rotary encoder (incremental type) for microscopic current circuits, used in electronic equipment.

1-2 標準状態 Standard atmospheric conditions

測定は特に指定のない限り、次の状態で行なう。  
Unless otherwise specified, the standard range of atmospheric conditions for making measurements and tests is as follows:

- 温度 Ambient temperature : 15°C to 35°C
- 相対湿度 Relative humidity : 25% to 85%
- 気圧 Air pressure : 86kPa to 106kPa

但し、疑義を生じた場合は、次の標準状態で行なう。

If there is any doubt about the results, measurements shall be made within the following limits:

- 温度 Ambient temperature : 20 ± 1°C
- 相対湿度 Relative humidity : 63% to 67%
- 気圧 Air pressure : 86kPa to 106kPa

1-3 使用温度範囲

Operating temperature range : -10°C to +70°C

1-4 保存温度範囲

Storage temperature range : -40°C to +85°C

2. 構造 Construction

2-1 寸法 Dimensions

添付組立図による。  
Refer to attached drawings.

3. 定格 Rating

3-1 定格電圧

Rated voltage : D. C. 5V

3-2 定格電流 (抵抗負荷)

operating current (resistive load)

- 各リード Each lead : 0.5mA (MAX 5mA, MIN 0.5mA)
- コモンリード Common lead : 1mA (MAX 10mA, MIN 0.5mA)

					 <b>ALPS ELECTRIC CO., LTD.</b>			
					APPD.	CHKD.	DSGD.	TITLE
					1-DSG2	1-DSG2	1-DSG2	ROTATIONAL ENCODER
					K.	H.		回転形エンコーダ
					Kawasaki	Shimomura	Y. KANZAKI	DOCUMENT NO.
					'97/8/07	'97/8/07	'97/8/06	4LE2124-5 ( / )
SYMB	DATE	APPD	CHKD	DSGD				

4. 電気的性能 Electrical characteristics

項目 Item	条件 Conditions	規格 Specifications													
4-1 出力信号 Output signal format	<p>&lt;Fig 1&gt;</p> <table border="1"> <thead> <tr> <th>軸回転方向 Shaft rotational direction</th> <th>信号 Signal</th> <th>出力波形 Output</th> </tr> </thead> <tbody> <tr> <td rowspan="2">時計方向 C. W.</td> <td>A (A-C端子間) A(Terminal A-C)</td> <td>OFF ON </td> </tr> <tr> <td>B (B-C端子間) B(Terminal B-C)</td> <td>OFF ON </td> </tr> <tr> <td rowspan="2">反時計方向 C. C. W.</td> <td>A (A-C端子間) A(Terminal A-C)</td> <td>OFF ON </td> </tr> <tr> <td>B (B-C端子間) B(Terminal B-C)</td> <td>OFF ON </td> </tr> </tbody> </table>	軸回転方向 Shaft rotational direction	信号 Signal	出力波形 Output	時計方向 C. W.	A (A-C端子間) A(Terminal A-C)	OFF ON	B (B-C端子間) B(Terminal B-C)	OFF ON	反時計方向 C. C. W.	A (A-C端子間) A(Terminal A-C)	OFF ON	B (B-C端子間) B(Terminal B-C)	OFF ON	<p>A, B2信号の位相差出力とし、詳細は&lt;fig. 1&gt;の通りとする。 クリック付きの場合クリック位置にてA信号は出力OFFの安定位置にあることB信号は規定せず。(破線はクリック付きの場合のクリック位置を示す。 2 Phase-different signals (Signal A signal B) Details shown in &lt;fig. 1&gt;. (The detent position will always be aligned with A-phase but B-phase has no specification. (The broken line shows detent position of with-detent type.</p>
軸回転方向 Shaft rotational direction	信号 Signal	出力波形 Output													
時計方向 C. W.	A (A-C端子間) A(Terminal A-C)	OFF ON													
	B (B-C端子間) B(Terminal B-C)	OFF ON													
反時計方向 C. C. W.	A (A-C端子間) A(Terminal A-C)	OFF ON													
	B (B-C端子間) B(Terminal B-C)	OFF ON													
4-2 分解能 Resolution	1回転にて出力されるパルス数 Number of pulses in 360° rotation.	各相 24パルス/360° 24 pulses/360° for each phase													
4-3 スイッチング特性 Switching characteristics	<p>下記測定回路&lt;fig. 2&gt;を用い、回転軸を360°・S<sup>-1</sup>の速さで回転し測定する。 Measurement shall be made under the condition as follows. 1) Shaft rotational speed : 360°・S<sup>-1</sup> 2) Test circuit : &lt;fig. 2&gt;</p> <p>&lt;fig. 2&gt;</p> <p>&lt;fig. 3&gt;</p> <p>(注記) コードON状態 : 出力電圧が1.5V以下の状態を言う。コードOFF状態 : 出力電圧が3.5V以上の状態を言う。 (note) Code-ON area : The area which the voltage is 1.5V or less. Code-OFF area : The area which the voltage is 3.5V or more.</p>	<p>t<sub>1</sub>, t<sub>3</sub> ≤ 3ms クリック付きの場合、クリック位置でのB相信号のチャタリングは規定せず。 B phase at detent position has no specification with-detent type.</p>													
1) チャタリング Chattering	<p>コードのOFF→ON及びON→OFFの際の、出力1.5V~3.5Vの通過時間に規定する。 Specified by the signal's passage time from 3.5V to 1.5V or from 1.5V to 3.5V of each switching position (code OFF→ON or ON→OFF).</p>														



**ALPS ELECTRIC CO., LTD.**

APPD.	CHKD.	DSGD.	TITLE
1-DSG2	1-DSG2	1-DSG2	ROTATIONAL ENCODER
K. Kawasaki	H. Shimomura	Y. KANZAKI	回転形エンコーダ
SYMB	DATE	APPD	CHKD
	'97/8/07		
			DSGD
			DOCUMENT NO.
			4LE2124-5 ( / )

項目 Item	条件 Conditions	規格 Specifications
2) 揺動ノイズ (バウンス) Sliding noise (Bounce)	コードONの部分の1.5V以上の電圧変動時間とし、チャタリング $t_1$ 、 $t_3$ 両者との間に1mS以上の1.5V以下のON部分を有するものとする。また、揺動ノイズ間に1.5V以下の範囲が1mSある場合は、別の揺動ノイズと判断する。 Specified by the time of voltage change exceed 1.5V in code-ON area. When the bounce has code-ON time less than 1mS between chattering ( $t_1$ or $t_3$ ), the voltage change shall be regarded as a part of chattering. When the code-ON time between 2 bounces is less than 1mS, they are regarded as 1 linked bounce.	$t_2 \leq 2mS$
3) 揺動ノイズ Sliding noise	コードOFFの部分の電圧変動 The voltage change in code-OFF area.	3.5V以上 3.5V MIN.
4-4 耐電圧 Dielectric strength	端子-取付板間にA. C. 50V1分間印加する。(リーク電流1mA) A voltage of 50V A.C. shall be applied for 1min between individual terminals and bracket. (Leak current 1mA)	絶縁破壊のないこと。 Without arcing or breakdown.
4-5 絶縁抵抗 Insulation resistance	端子-取付板間にD. C. 50V印加する。 Measurement shall be made under the condition which a voltage of 50V D.C. is applied between individual terminals and bracket.	端子-取付板間にて10M $\Omega$ 以上 Between individual terminals and bracket: 10M $\Omega$ MIN.
4-6 位相差 Phase-difference	定速で操作軸を回転する。 Measurement shall be made under the condition which the shaft is rotated in constant speed.  <fig. 4> 時計方向 CW A信号 (A-C間) Signal A B信号 (B-C間) Signal B  反時計方向 CCW A信号 (A-C間) Signal A B信号 (B-C間) Signal B  	<fig. 4>において $\Delta T = 0.08T$ 以上 MIN In <fig. 4>

					<b>ALPS ELECTRIC CO., LTD.</b>			
					APPD.	CHKD.	DSGD.	TITLE
					1-DSG2	1-DSG2	1-DSG2	ROTATIONAL ENCODER
					K. Kawasaki	H. Shimomura	Y. KANZAKI	回転形エンコーダ
					'97/8/07	'97/8/07	'97/8/06	DOCUMENT NO.
SYMB	DATE	APPD	CHKD	DSGD				4LE2124-5 ( / )

5. 機械的性能 Mechanical characteristics

項目 Item	条件 Conditions	規格 Specifications
5-1 全回転角度 Total rotational angle		360° (エンドレス) 360° (Endless)
5-2 クリックトルク Detent torque	(クリック付きのみ適用) (Applied for with-detent type)	3 ~20mN・m (30.1~200.4gf・cm)  但し、-10° C~+5° Cでは、軸が回転すること。 Shaft rotatable at -10° C~+5° C.
5-3 クリック点数及び位置 Number and position of detents.	(クリック付きのみ適用) (Applied for with-detent type)	24点クリック 24 detents (ステップ角度 15° ±3°) (Step angle:15° ±3°)
5-4 軸の押し引き強度 Push-pull strength of shaft	軸の押し及び引き方向に50N (5.1kgf)の静荷重を10秒間加える。(PCB半田付け後) Push and pull static load of 50N shall be applied to the shaft in the axial direction for 10S. (After soldering of the PC board)	軸の破損、著しい回転ムラ、ガタ等の異常がなく電気的性能を満足すること。 Without damage to, or excessive play in shaft. No excessive abnormality in rotational feeling. And electrical characteristics shall be satisfied.
5-5 端子強度 Terminal strength	端子先端の任意の方向に3N (0.31kgf)の静荷重を10秒間加える。 A static load of 3N shall be applied to the tip of terminals for 10S in any direction.	著しいガタ及び接触不良を生じないこと。 Without excessive play in terminals or poor contact.
5-6 軸ガタ Shaft wobble	軸先端から5mmの位置に5N・m (0.51kgf・cm)の曲げモーメントを加える。 A momentary load of 5N・m shall be applied at the point 5mm from the tip of the shaft in a direction perpendicular to the axis of shaft.	1.0×L/30mm-p以内 1.0×L/30mm-p MAX. (Lは取付長さで比例計算する。) (L:Shaft length)
5-7 軸の垂直押し強度 Side thrust strength of shaft	軸先端から5mmの位置に20N (2.04kgf)の静荷重を10秒間加える。(PCB半田付け後) A load of 20N shall be applied at the point 5mm from the tip of the shaft in a direction perpendicular to the axis of shaft. (After soldering of the PC board)	著しいガタ及び、曲がりのないこと。 又、機械的に異常のないこと。 Without excessive play or bending in shaft. No mechanical abnormality.
5-8 軸の回転方向ガタ Shaft play in rotational wobble	角度板にて測定する。 Measure with jig for rotational angle	4° 以内。 4° MAX

 <b>ALPS ELECTRIC CO., LTD.</b>				
APPD.	CHKD.	DSGD.	TITLE ROTATIONAL ENCODER	
1-DSG2	1-DSG2	1-DSG2	回転形エンコーダ	
K. Kawasaki	H. Shimomura	Y. KANZAKI	DOCUMENT NO.	
'97/8/07	'97/8/07	'97/8/06	4LE2124-5 ( / )	
SYMB	DATE	APPD	CHKD	DSGD

	項目 Item	条 件 Conditions	規 格 Specifications
5-9	はんだ耐熱 Resistance to soldering heat	7項の“はんだ付け条件”による。 Specified by the clause 7 "Soldering conditions".	はんだ付け後、電気的性能を満足すること。また、著しいガタ等機械的に異常のないこと。 Electrical characteristics shall be satisfied. No mechanical abnormality such as a excessive play.

					 <b>ALPS ELECTRIC CO., LTD.</b>			
					APPD.	CHKD.	DSGD.	TITLE ROTATIONAL ENCODER
					1-DSG2	1-DSG2	1-DSG2	回転形エンコーダ
					K. Kawasaki	H. Shimomura	Y. KANZAKI	DOCUMENT NO.
SYMB	DATE	APPD	CHKD	DSGD	' 97/8/07	' 97/8/07	' 97/8/06	4LE2124-5 ( / )

6. 耐久性能 Endurance characteristics.

項目 Item	条件 Conditions	規格 Specifications
6-1 寿命性能 Rotational life	無負荷で軸を600~1000/Hの速さで、30,000回往復回転動作を行う。 The shaft of encoder shall be rotated to 30,000 cycles at a speed of 600~1000/H without electrical load, after which measurements shall be made.	チャタリング $t_1, t_3 \leq 5mS$ バウンス $t_2 \leq 3mS$ Chattering $t_1, t_3 \leq 5mS$ Bounce $t_2 \leq 3mS$ クリック感が残っていること。 (クリック付きのみ適用) Detent feeling has to remain. (Applied for detent type)
6-2 耐湿性 Damp heat	温度 $40 \pm 2^\circ C$ 、湿度90~95%の恒温湿槽中に $240 \pm 10$ 時間放置後、常温、常湿中に1.5時間放置する。 The encoder shall be stored at a temperature of $40 \pm 2^\circ C$ with relative humidity of 90% to 95% for $240 \pm 10H$ in a thermostatic chamber. And then the encoder shall be subjected to standard atmospheric conditions for 1.5H, after which measurement shall be made.	初期規格を満足すること。 Specifications in clause 4.1~4.5 and 5.1~5.3 shall be satisfied
6-3 耐熱特性 Dry heat	温度 $85 \pm 3^\circ C$ の恒温槽中に $240 \pm 10$ 時間放置後、常温、常湿中に1.5時間放置する。 The encoder shall be stored at a temperature of $85 \pm 3^\circ C$ for $240 \pm 10H$ in a thermostatic chamber. And then the encoder shall be subjected to standard atmospheric conditions for 1.5H, after which measurements shall be made.	初期規格を満足すること。 Specifications in clause 4.1~4.5 and 5.1~5.3 shall be satisfied.
6-4 低温特性 Cold	温度 $-40 \pm 3^\circ C$ の恒温槽中に $240 \pm 10$ 時間放置後、常温、常湿中に1.5時間放置する。 The encoder shall be stored at a temperature of $-40 \pm 3^\circ C$ for $240 \pm 10H$ in a thermostatic chamber. And then the encoder shall be subjected to standard atmospheric conditions for 1.5H, after which measurement shall be made.	初期規格を満足すること。 Specifications in clause 4.1~4.5 and 5.1~5.3 shall be satisfied.
6-5 耐落下性 Free falling	60cmの高さより製品の任意の方向からビニタイルを張ったコンクリートの床上に自由に落下させる。 The encoder shall be fallen freely at any posture from 60cm height to the concrete floor covered with vinyl-tile, after which measurement shall be made.	著しい変形、破損等がなく初期規格を満足すること。 (但し、端子部の変形は除く。) No excessive deformation or damage. (Except the deformation of terminals.) And specifications in clause 4.1~4.5 and 5.1~5.3 shall be satisfied.
6-6 耐振性 Vibration	10~55~10Hzと変化する振動(1周期1分/振幅1.5mm)をX、Y、Z、各方向に2時間加える。 The following vibration shall be applied to the encoder, after which measurement shall be made: The entire frequency range, from 10Hz to 55Hz and return to 10Hz, shall be transversed in 1 min. Amplitude (total excursion): 1.5mm. This motion shall be applied for a period of 2H in each of 3 mutually perpendicular axes (A total of 6H).	初期規格を満足すること。 Specifications in clause 4.1~4.5 and 5.1~5.3 shall be satisfied.

 <b>ALPS ELECTRIC CO., LTD.</b>				
APPD.	CHKD.	DSGD.	TITLE ROTATIONAL ENCODER	
1-DSG2	1-DSG2	1-DSG2	回転形エンコーダ	
K.	H.	Y. KANZAKI	DOCUMENT NO.	
Kawasaki	Shimomura	' 97/8/07	4LE2124-5 ( / )	
SYMB	DATE	APPD	CHKD	DSGD



7. はんだ付け条件 Soldering conditions

7-1 手はんだの場合 Manual soldering

温度300°C以下、時間3秒以内

Bit temperature of soldering iron : 300°C or less.

Application time of soldering iron : within 3s.

7-2 ディップはんだの場合 Dip soldering

使用基板 : t1. 6片面銅張り積層板

Printed wiring board: Single-sided copper clad laminate board with thickness of 1.6mm.

フラックス : 比重0.82以上のフラックスを用い発泡式フラクサーにて発泡面高さは、基板板厚の半分を目安とし、かつ基板表面にフラックスの流入がないこと。

Flux:

・Specific gravity: 0.82 or more.

・Flux shall be applied to the board using a bubble foaming type fluxer.

・The board shall be soaked in the flux bubble only to the middle of its thickness.

・Flux shall not come into contact with the component side surface.

プリヒート : 基板表面温度100°C以下、時間1分以内

Preheating:

・Surface temperature of board: 100°C or less.

・Preheating time: within 1 min.

はんだ : 温度260°C±5°C、時間3秒±1秒以内

Soldering:

・Solder temperature: 260°C ±5°C.

・Immersion time: Within 3±1s

以上の工程を1回または2回通過する。

Apply the above soldering process for 1 or 2 times.

8. はんだ付け時のご注意事項 Note for soldering method.

8-1 下図のようにP. C. B. の上にはんだ付けをする配線は、お避けください。

Please avoid soldering on upper surface (the component side surface) of the PC board as shown below.

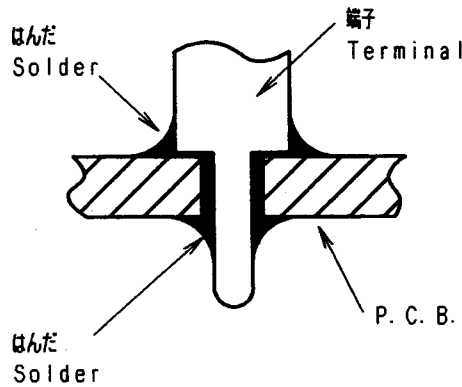

8-2 半田ディップ後の洗浄についてはエンコーダ内にフラックスが流入する場合があります。

接触不良の原因となりますのでご注意ください。

Please avoid cleaning of PCB board because the flux used during the dip soldering process may enter the encoder and cause poor contact

					<b>ALPS ELECTRIC CO., LTD.</b>			
					APPD.	CHKD.	DSGD.	TITLE
					1-DSG2	1-DSG2	1-DSG2	ROTATIONAL ENCODER
					K.	H.	Y. KANZAKI	回転形エンコーダ
					Kawasaki	Shimomura		DOCUMENT NO.
					'97/8/07	'97/8/07	'97/8/06	4LE2124-5 ( / )
SYMB	DATE	APPD	CHKD	DSGD				

### 9. その他、取扱い上のご注意 PRECAUTIONS IN USE

- 9-1. 保管は高温、多湿の場所及び腐食性ガス中を避けて下さい。  
During operation, storage in high temperature and humidity, and in corrosive gas, should be avoided.
- 9-2. エンコーダのハルスカウント処理の設計においては動作スピード、サンプリングタイム、マスキングタイム等に注意し、実装確認の上御使用願います。  
At design of the pulse count process, care should be taken with operational speed, sampling time, and masking time etc.
- 9-3. 本製品はクリック位置にてA相はOFF状態で安定となりますので、ソフト設計時A相基準で設計願います。  
With this part, detent position will always be aligned with A-OFF phase, therefore make the A phase the reference at the soft ware design stage.
- 9-4. エンコーダのハルスカウント処理の回路は下図のフィルターをいれることを推奨します。  
At design of the pulse count process, using the C/R filter circuit as below is recommended.

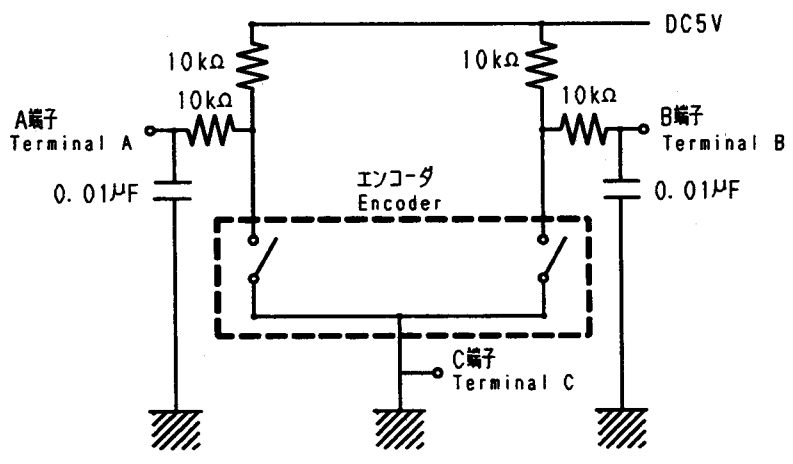

- 9-4. 本製品の本体に直接水分がかかると、ハルス波形に異常が発生する可能性がありますので、製品に直接水分がかからないよう配慮願います。  
Care must be taken not to expose this product to water or dew to prevent possible problem in pulse output wave form.
- 9-5. 本製品は軸に対し過度の横押し力が加わりますと、製品機能を損ねる恐れがありますので、あらかじめつまみにガイドを設ける等の配慮をお願いします。  
Consideration to provide protective guard for knob is highly recommended to avoid side pressure to the shaft.
- 9-6. 本製品は軸に対し過度の衝撃力が加わりますと、製品機能を損ねる恐れがありますので、ご注意下さい。  
Excessive impact force may decrease the performance of this product. Please pay attention to impact force.

					<b>ALPS ELECTRIC CO., LTD.</b>			
					APPD.	CHKD.	DSGD.	TITLE ROTATIONAL ENCODER
					1-DSG2	1-DSG2	1-DSG2	回転形エンコーダ
					K. Kawasaki	H. Shimomura	Y. KANZAKI	DOCUMENT NO.
					'97/8/07	'97/8/07	'97/8/06	4LE2124-5 ( / )
SYMB	DATE	APPD	CHKD	DSGD				

CLASS No.	TITLE プッシュモーメンタリスイッチ規格書 PUSH MOMENTARY SWITCH SPECIFICATION	(SW02)
-----------	---	--------

1. 定格容量 (抵抗負荷)  
Switch rating (Resistor load) D. C. 5V10mA (1mA MIN)

2. 電気的性能 Electrical characteristics

項目 Item	条件 Conditions	規格 Specifications
2-1 接触抵抗 Contact resistance	D. C. 5V1mA電圧降下法にて測定する。 Measured by the 1mA 5V D. C. voltage drop method.	100mΩ MAX.
2-2 チャタリング Chattering	1サイクル (OFF-ON-OFF) 1秒で動作させる。 Switch is operated at the rate of 1 cycle 1 sec. The 1 cycle shall be OFF-ON-OFF.	10msec以下 Less than 10msec
2-3 絶縁抵抗 Insulation resistance	端子-取付板間にD. C. 50V1mA印加する。 Measurement shall be made under the condition which a voltage of 50VD. C. 1mA is applied between individual terminals and bracket.	端子-取付板間に10MΩ以上 Between individual terminals and bracket: 10MΩ MIN.
2-4 耐電圧 Dielectric strength	端子-取付板間にA. C. 50V1分間又は、A. C. 60V2秒間印加する。 (リーク電流1mA) A voltage of 50VA. C. shall be applied for 1min or a voltage of 60VA. C. shall be applied for 2sec between individual terminals and bracket. (Leak current:1mA)	損傷・アーク・絶縁破壊がないこと。 Without damage to parts, arcing or breakdown.

注記:  
Note: 軸・スイッチ端子間は絶縁されております。  
Shaft is insulated from switch terminal.

3. 機械的性能 Mechanical characteristics

項目 Item	条件 Conditions	規格 Specifications
3-1 スイッチ回路・接点数 Contact arrangement		単極単投 (Push on) S. P. S. T. (Push on)
3-2 スイッチ移動量 Switching		0. 5 <sup>+0.4</sup> <sub>-0.3</sub> mm
3-3 スイッチ作動力 Switch operation force		3 <sup>+1.5</sup> <sub>-1.0</sub> N (306 <sup>+153</sup> <sub>-102</sub> gf)

4. 耐久性能 Endurance characteristics.

項目 Item	条件 Conditions	規格 Specifications
4-1 寿命特性 Operating life	無負荷にて軸を毎時500回の速さで20,000回断続動作を行う。 但し、試験途中5,000で中間測定を行う。(軸押し力は1Kgf・cm以下) The shaft of switch shall be 20,000 times at a speed of 500times per hour without electrical load, after which measurements shall be made. However, an interim measurement shall be made immediately after 5,000 times. (strength of shaft 1Kgf・cmMAX)	接触抵抗: 200mΩ以下 その他、初期規格を満足すること。 Switch contact resistance: 200mΩMAX. Except above items, specifications in clause 2. 2~4, and 3. 1~3 shall be satisfied.

 <b>ALPS ELECTRIC CO., LTD.</b>				
APPD.	CHKD.	DSGD.	TITLE	
1-DSG2	1-DSG2	1-DSG2	プッシュモーメンタリスイッチ PUSH MOMENTARY SWITCH	
K. Kawasaki	H. Shimomura	Y. KANZAKI	DOCUMENT NO.	
'97/8/07	'97/8/07	'97/8/06	4LE2124-5 (1)	
SYMB	DATE	APPD	CHKD	DSGD

OR

この間は $\phi 6^{-0.05}$   
WITHIN THIS LENGTH

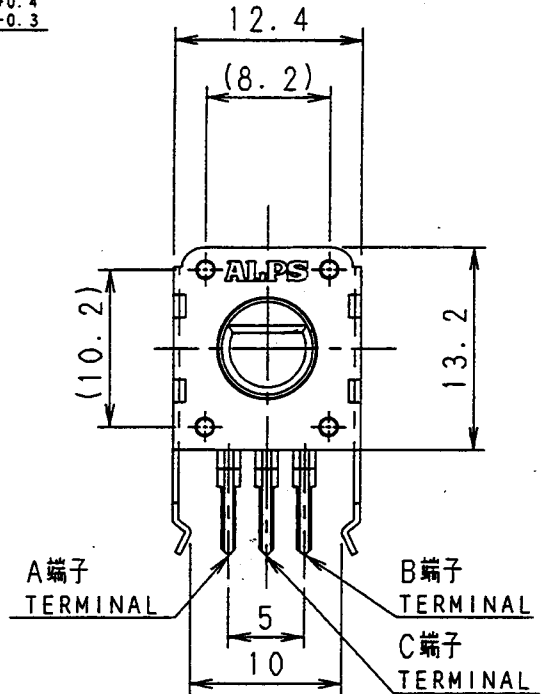
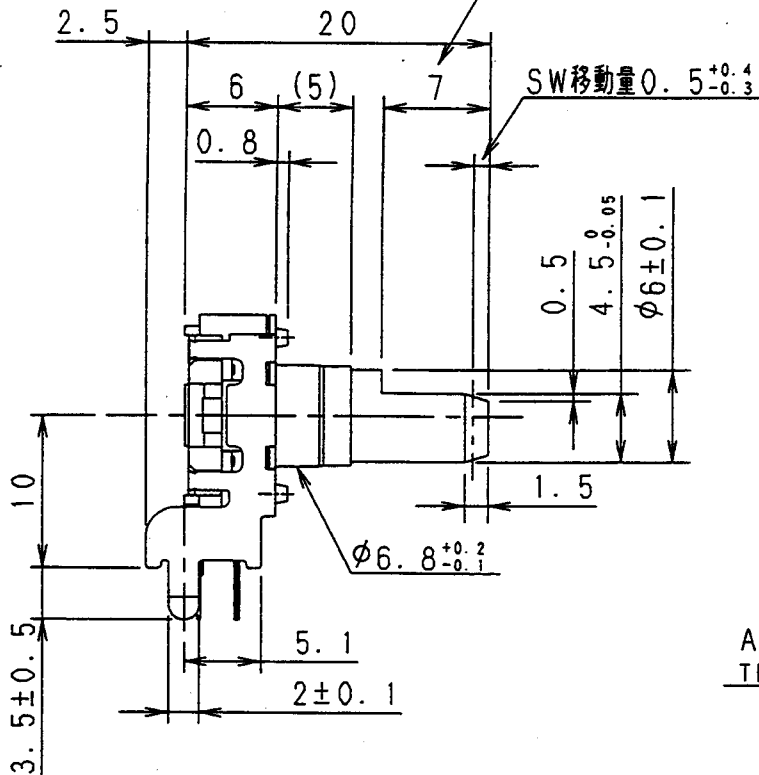

取付穴寸法図 (許容差 $\pm 0.1$ )

※挿入側より見た図  
P. W. B. MOUNTING DETAIL  
(TOLERANCE $\pm 0.1$ )  
VIEWED FROM MOUNTING SIDE

端子先端詳細図 (10:1)

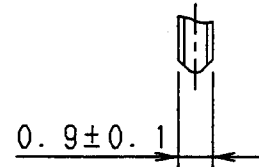
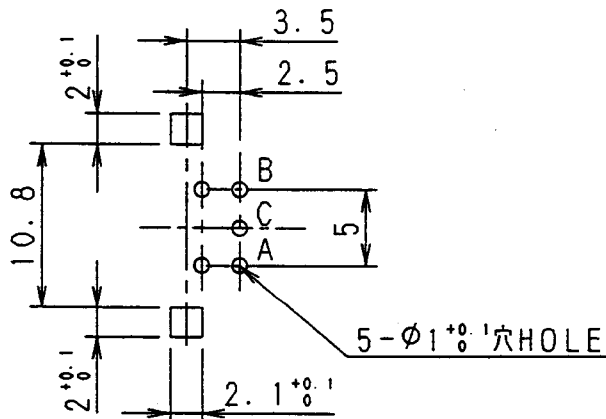

基板板厚  $t = 1.6 \text{ mm}$   
P. C. B.

指定なき部分の許容差 TOLERANCES UNLESS OTHERWISE SPEC	
$L \leq 10$	$\pm 0.3$
$10 < L < 100$	$\pm 0.5$
$100 \leq L$	$\pm 0.8$
角度 ANGULAR DIMENSION	$\pm 5^\circ$

			24パルス SHAFT COLOR: BLACK		L=20 立形 クリック付
PART NO.	NAME	MATERIAL NAME / CODE	FINISH		
<b>ALPS ELECTRIC CO., LTD.</b>					
DSGD. セツケ12-7361009 T. SUZUKI 97-10-16			SCALE 2:1	NO.	
CHKD. H. Shimomura 97-10-16				TITLE 12形薄形エンコーダ	
APPD. K. Kawasaki 97-10-17			UNIT mm	DOCUMENT NO. LE21240A	
SYMB	DATE	APPD	CHKD	DSGD	

2.6g

OR