

DATE	DESCRIPTION	REV.

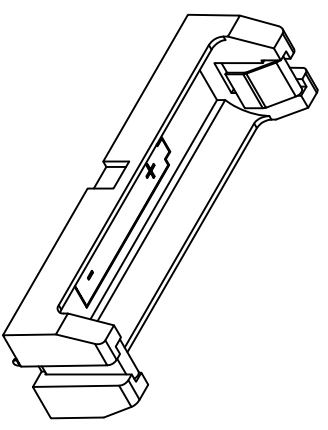
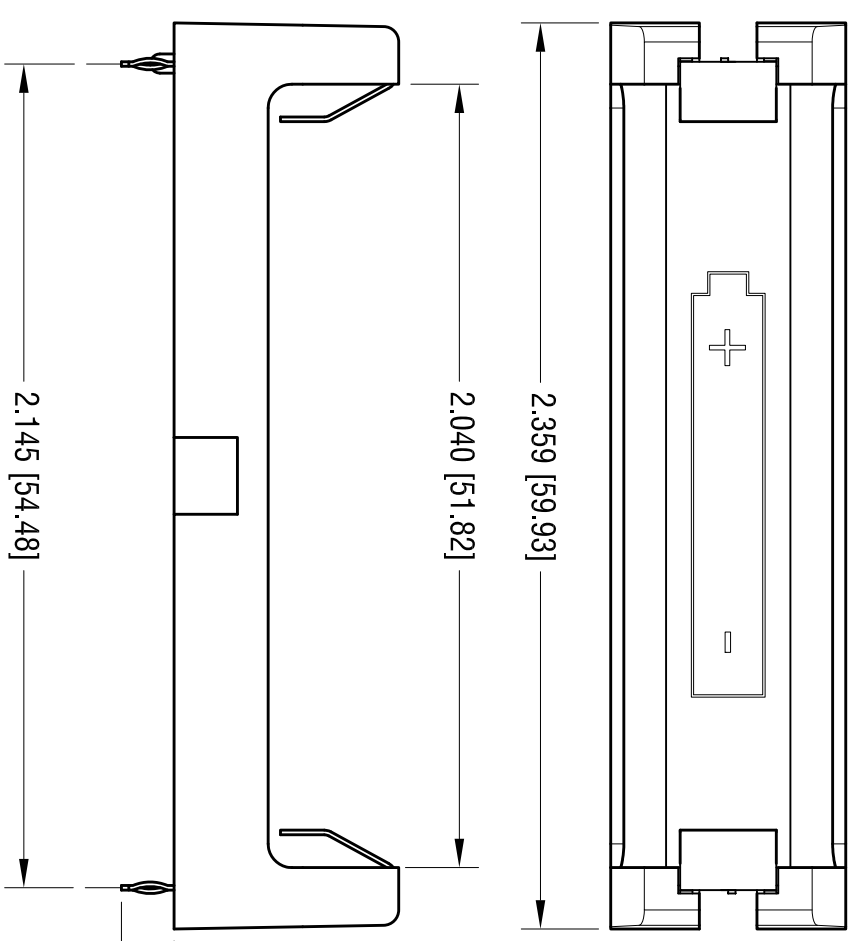
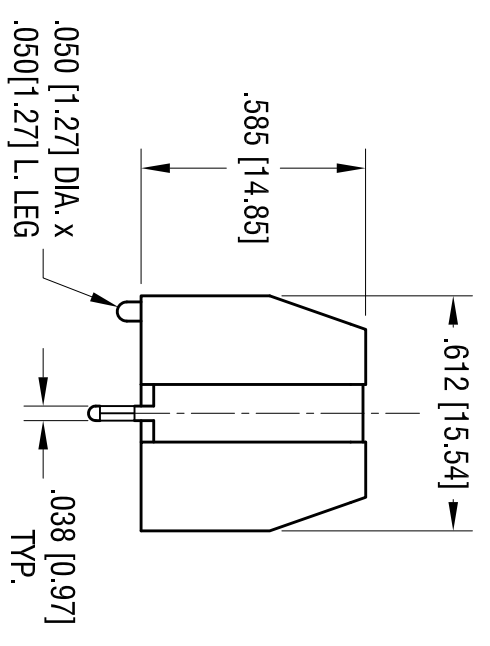
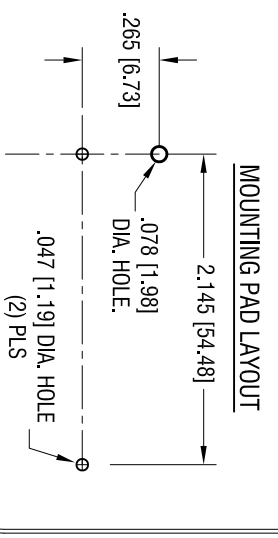

- NOTE:
1. BASE:
MATERIAL: HEAT RESISTANCE NYLON
STANLYL 46 OR EQUIVALENT
 2. CONTACT:
MATERIAL: .012 [0.30] THK PHOSPHOR BRONZE
FINISH: TIN NICKEL PLATE PLATE.

THIS DOCUMENT IS THE PROPERTY OF KEYSTONE ELECTRONICS CORP. AND SHALL NOT BE REPRODUCED, DISTRIBUTED OR USED AS A BASIS FOR MANUFACTURE WITHOUT PRIOR WRITTEN PERMISSION FROM KEYSTONE ELECTRONICS CORP.

KEYSTONE ELECTRONICS CORP.			
www.keystec.com • ASTORIA, N.Y. 11105-2017 • Tel (718) 956-8900			
PART NAME		THM BATTERY HOLDER, AA	
MATERIAL		AS NOTED	
FINISH	AS NOTED	DRN BY	NT
TOLERANCES	INCH [MM]	DATE	3.11.10
DECIMAL	± .010 [± 0.25]	App'D	LN
ANGULAR	± 1°	SCALE	2X
		CODE	DWG NO.
		C	1015