

THIS DOCUMENT IS THE PROPERTY OF
KEYSTONE ELECTRONICS CORP. AND
SHALL NOT BE REPRODUCED, DISTRIBUTED
OR USED AS A BASIS FOR MANUFACTURE
WITHOUT PRIOR WRITTEN PERMISSION
FROM KEYSTONE ELECTRONICS CORP.

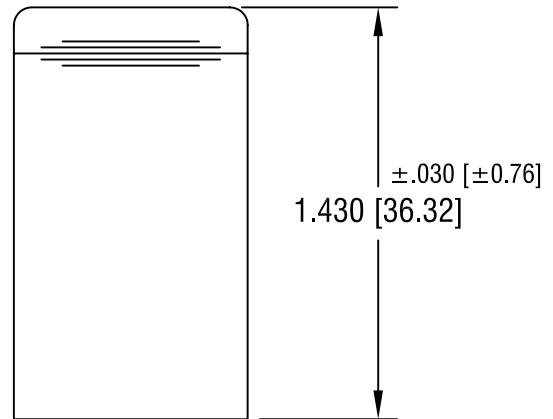
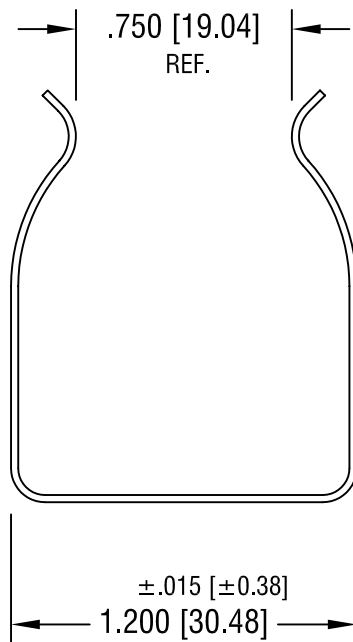
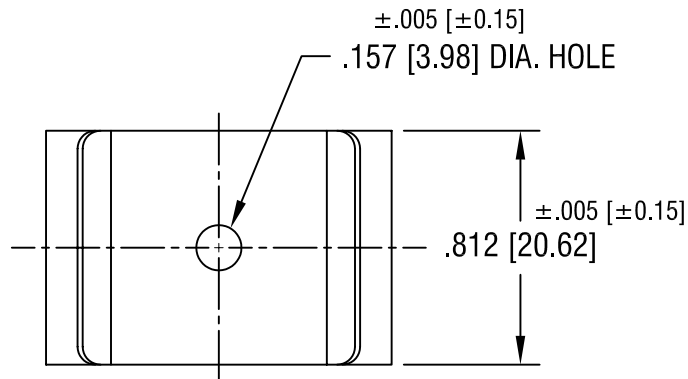

NOTE:

1. HEAT TREAT TO SPRING TEMPER.

4.10.03	CHANGE AS PER ECN 03-033	C
DATE	DESCRIPTION	REV.

KEYSTONE ELECTRONICS CORP.			
ASTORIA, N.Y. 11105-2017			
PART NAME		COMPONENT CLIP	
MATERIAL			
.025 [.63] TH'K ANNEALED SPRING STEEL			
FINISH		DRN BY	DATE
NICKEL PLATE		BOONE	2.3.73
		APPD	SCALE
			1.5X
TOLERANCES	INCH [MM]	CODE	DWG NO.
DECIMAL	± .010 [± 0.25]	C	217
ANGULAR	± 1°		
UNLESS OTHERWISE SPECIFIED			