

THIS DOCUMENT IS THE PROPERTY OF KEYSTONE ELECTRONICS CORP. AND SHALL NOT BE REPRODUCED, DISTRIBUTED OR USED AS A BASIS FOR MANUFACTURE WITHOUT PRIOR WRITTEN PERMISSION FROM KEYSTONE ELECTRONICS CORP.

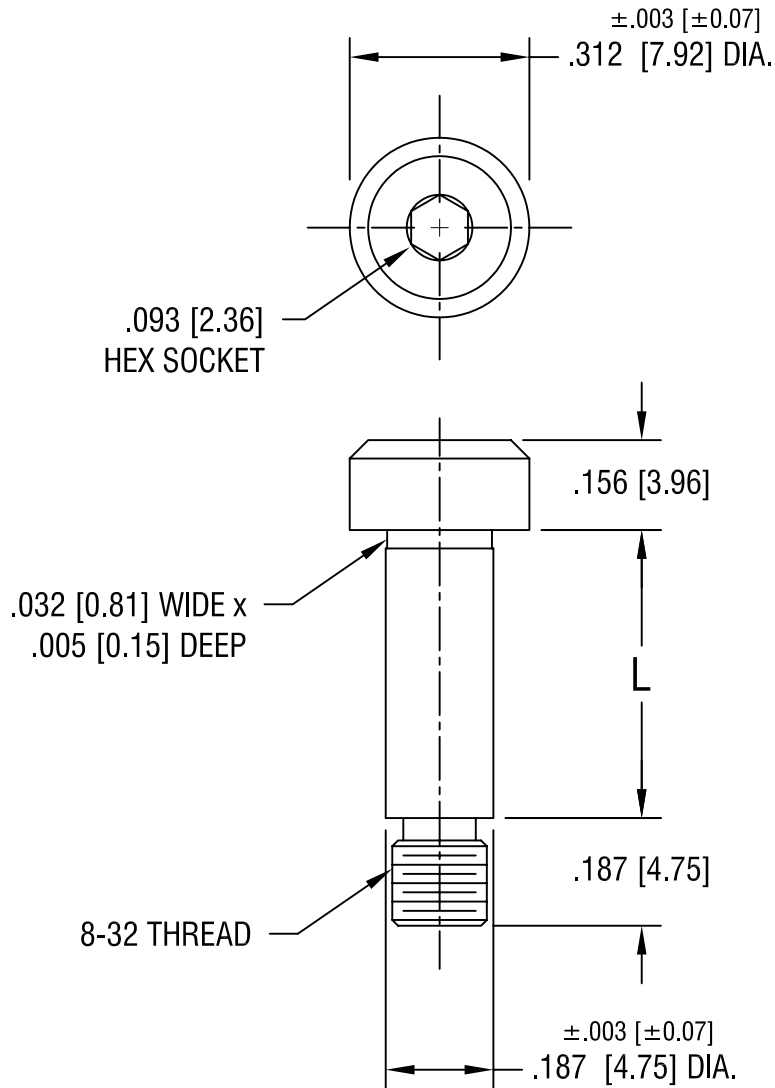

PART NO.	'L' DIM.
2451	.125 [3.17]
2452	.250 [6.35]
2453	.375 [9.52]
2454	.500 [12.70]
2455	.625 [15.87]
2456	.750 [19.05]
2457	1.000 [25.40]

KEYSTONE ELECTRONICS CORP.

ASTORIA, N.Y. 11105-2017

PART NAME

SHOULDER SCREW - SOCKET

MATERIAL

STAINLESS STEEL

FINISH

-

DRN BY

BOONE

DATE

8.16.95

APPD

SCALE

3X

TOLERANCES

INCH [MM]

DECIMAL $\pm .005$ [± 0.15]

ANGULAR $\pm 1^\circ$

UNLESS OTHERWISE SPECIFIED

CODE

C/M

DWG NO.

2451-2457

DATE

DESCRIPTION

REV.