

THIS DOCUMENT IS THE PROPERTY OF
KEYSTONE ELECTRONICS CORP. AND
SHALL NOT BE REPRODUCED, DISTRIBUTED
OR USED AS A BASIS FOR MANUFACTURE
WITHOUT PRIOR WRITTEN PERMISSION
FROM KEYSTONE ELECTRONICS CORP.

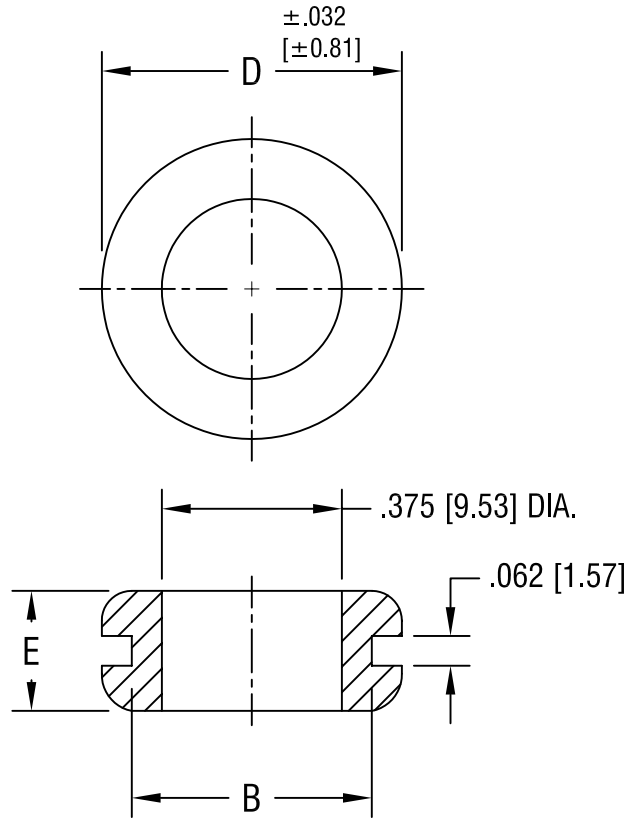

PART NO.	'B' DIA.	'D' DIA.	'E' DIM.
744	.625 [15.88]	.875 [22.23]	.312 [7.92]
745	.500 [12.70]	.625 [15.88]	.250 [6.35]

KEYSTONE ELECTRONICS CORP.

ASTORIA, N.Y. 11105-2017

PART NAME

RUBBER GROMMET

MATERIAL

BUNA S

FINISH

-

DRN BY

BOONE

DATE

9.16.96

APPD

SCALE

2.5X

TOLERANCES

INCH [MM]

DECIMAL $\pm .020$ [± 0.50]

ANGULAR $\pm 1^\circ$
UNLESS OTHERWISE SPECIFIED

CODE

C/M

DWG NO.

744-745

DATE

DESCRIPTION

REV.