



# STGW40NC60V

N-CHANNEL 50A - 600V - TO-247

Very Fast PowerMESH™ IGBT

**Table 1: General Features**

TYPE	V <sub>CES</sub>	V <sub>CE(sat)</sub> (Max) @25°C	I <sub>C</sub> @100°C
STGW40NC60V	600 V	< 2.5 V	50 A

- HIGH CURRENT CAPABILITY
- HIGH FREQUENCY OPERATION UP TO 50 KHz
- LOSSES INCLUDE DIODE RECOVERY ENERGY
- OFF LOSSES INCLUDE TAIL CURRENT
- LOWER C<sub>RES</sub> / C<sub>IES</sub> RATIO
- NEW GENERATION PRODUCTS WITH TIGHTER PARAMETER DISTRIBUTION

## DESCRIPTION

Using the latest high voltage technology based on a patented strip layout, STMicroelectronics has designed an advanced family of IGBTs, the PowerMESH™ IGBTs, with outstanding performances. The suffix "V" identifies a family optimized for high frequency.

## APPLICATIONS

- HIGH FREQUENCY INVERTERS
- SMPS and PFC IN BOTH HARD SWITCH AND RESONANT TOPOLOGIES
- UPS
- MOTOR DRIVERS

**Table 2: Order Codes**

SALES TYPE	MARKING	PACKAGE	PACKAGING
STGW40NC60V	GW40NC60V	TO-247	TUBE

**Figure 1: Package**

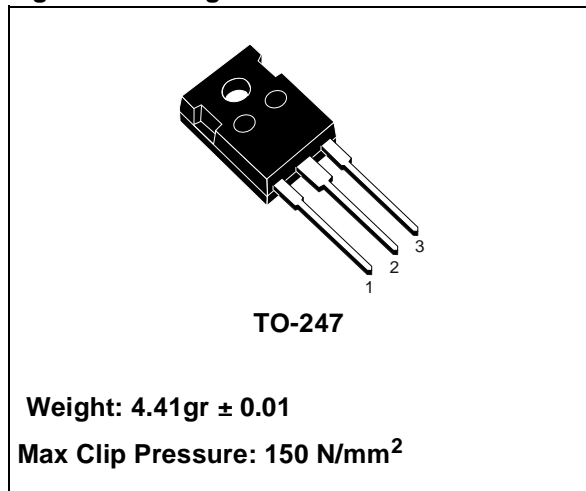

**Figure 2: Internal Schematic Diagram**

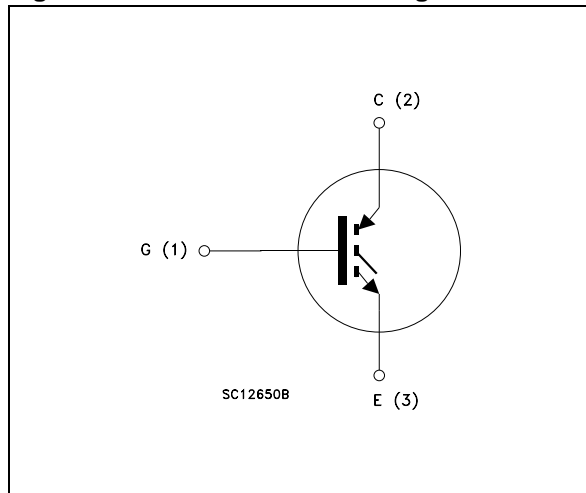

**Table 3: Absolute Maximum ratings**

Symbol	Parameter	Value	Symbol
V <sub>CES</sub>	Collector-Emitter Voltage (V <sub>GS</sub> = 0)	600	V
V <sub>ECR</sub>	Reverse Battery Protection	20	V
V <sub>GE</sub>	Gate-Emitter Voltage	± 20	V
I <sub>C</sub>	Collector Current (continuous) at 25°C (#)	80	A
I <sub>C</sub>	Collector Current (continuous) at 100°C (#)	50	A
I <sub>CM</sub> (1)	Collector Current (pulsed)	200	A
P <sub>TOT</sub>	Total Dissipation at T <sub>C</sub> = 25°C	260	W
	Derating Factor	2.08	W/°C
T <sub>stg</sub>	Storage Temperature	- 55 to 150	°C
T <sub>j</sub>	Operating Junction Temperature		

(1)Pulse width limited by max. junction temperature.

**Table 4: Thermal Data**

		Min.	Typ.	Max.	Unit
R <sub>thj-case</sub>	Thermal Resistance Junction-case			0.48	°C/W
R <sub>thj-amb</sub>	Thermal Resistance Junction-ambient			50	°C/W
T <sub>L</sub>	Maximum Lead Temperature for Soldering Purpose (1.6 mm from case, for 10 sec.)		300		°C

**ELECTRICAL CHARACTERISTICS (T<sub>CASE</sub> =25°C UNLESS OTHERWISE SPECIFIED)**
**Table 5: Off**

Symbol	Parameter	Test Conditions	Min.	Typ.	Max.	Unit
V <sub>BR(CES)</sub>	Collectro-Emitter Breakdown Voltage	I <sub>C</sub> = 1 mA, V <sub>GE</sub> = 0	600			V
I <sub>CES</sub>	Collector-Emitter Leakage Current (V <sub>CE</sub> = 0)	V <sub>GE</sub> = Max Rating T <sub>c</sub> =25°C T <sub>c</sub> =125°C			10 1	µA mA
I <sub>GES</sub>	Gate-Emitter Leakage Current (V <sub>CE</sub> = 0)	V <sub>GE</sub> = ± 20 V , V <sub>CE</sub> = 0			± 100	nA

**Table 6: On**

Symbol	Parameter	Test Conditions	Min.	Typ.	Max.	Unit
V <sub>GE(th)</sub>	Gate Threshold Voltage	V <sub>CE</sub> = V <sub>GE</sub> , I <sub>C</sub> = 250 µA	3.75		5.75	V
V <sub>CE(SAT)</sub>	Collector-Emitter Saturation Voltage	V <sub>GE</sub> = 15 V, I <sub>C</sub> = 40A, T <sub>j</sub> = 25°C V <sub>GE</sub> = 15 V, I <sub>C</sub> = 40A, T <sub>j</sub> = 125°C		1.9 1.7	2.5	V V

(#) Calculated according to the iterative formula:

$$I_C(T_C) = \frac{T_{JMAX} - T_C}{R_{THJ-C} \times V_{CESAT(MAX)}(T_C, I_C)}$$

## ELECTRICAL CHARACTERISTICS (CONTINUED)

Table 7: Dynamic

Symbol	Parameter	Test Conditions	Min.	Typ.	Max.	Unit
$g_{fs}(1)$	Forward Transconductance	$V_{CE} = 15 \text{ V}$ , $I_C = 20 \text{ A}$		20		S
$C_{ies}$ $C_{oes}$ $C_{res}$	Input Capacitance Output Capacitance Reverse Transfer Capacitance	$V_{CE} = 25 \text{ V}$ , $f = 1 \text{ MHz}$ , $V_{GE} = 0$		4550 350 105		pF pF pF
$Q_g$ $Q_{ge}$ $Q_{gc}$	Total Gate Charge Gate-Emitter Charge Gate-Collector Charge	$V_{CE} = 390 \text{ V}$ , $I_C = 40 \text{ A}$ , $V_{GE} = 15 \text{ V}$ , (see Figure 20)		214 30 96		nC nC nC
$I_{CL}$	Turn-Off SOA Minimum Current	$V_{clamp} = 480 \text{ V}$ , $T_j = 150^\circ\text{C}$ $R_G = 100 \Omega$ , $V_{GE} = 15 \text{ V}$	200			A

Table 8: Switching On

Symbol	Parameter	Test Conditions	Min.	Typ.	Max.	Unit
$t_{d(on)}$ $t_r$ $(di/dt)_{on}$ $E_{on}(2)$	Turn-on Delay Time Current Rise Time Turn-on Current Slope Turn-on Switching Losses	$V_{CC} = 390 \text{ V}$ , $I_C = 40 \text{ A}$ $R_G = 3.3 \Omega$ , $V_{GE} = 15 \text{ V}$ , $T_j = 25^\circ\text{C}$ (see Figure 18)		43 17 2060 330	450	ns ns A/ $\mu\text{s}$ $\mu\text{J}$
$t_{d(on)}$ $t_r$ $(di/dt)_{on}$ $E_{on}(2)$	Turn-on Delay Time Current Rise Time Turn-on Current Slope Turn-on Switching Losses	$V_{CC} = 390 \text{ V}$ , $I_C = 40 \text{ A}$ $R_G = 3.3 \Omega$ , $V_{GE} = 15 \text{ V}$ , $T_j = 125^\circ\text{C}$ (see Figure 18)		42 19 1900 640		ns ns A/ $\mu\text{s}$ $\mu\text{J}$

2)  $E_{on}$  is the turn-on losses when a typical diode is used in the test circuit in figure 2. If the IGBT is offered in a package with a co-pack diode, the co-pack diode is used as external diode. IGBTs & DIODE are at the same temperature ( $25^\circ\text{C}$  and  $125^\circ\text{C}$ )

Table 9: Switching Off

Symbol	Parameter	Test Conditions	Min.	Typ.	Max.	Unit
$t_r(V_{off})$ $t_{d(off)}$ $t_f$ $E_{off}(3)$ $E_{ts}$	Off Voltage Rise Time Turn-off Delay Time Current Fall Time Turn-off Switching Loss Total Switching Loss	$V_{CC} = 390 \text{ V}$ , $I_C = 40 \text{ A}$ , $R_{GE} = 3.3 \Omega$ , $V_{GE} = 15 \text{ V}$ $T_j = 25^\circ\text{C}$ (see Figure 18)		25 140 45 720 1050	970 1420	ns ns ns $\mu\text{J}$ $\mu\text{J}$
$t_r(V_{off})$ $t_{d(off)}$ $t_f$ $E_{off}(3)$ $E_{ts}$	Off Voltage Rise Time Turn-off Delay Time Current Fall Time Turn-off Switching Loss Total Switching Loss	$V_{CC} = 390 \text{ V}$ , $I_C = 40 \text{ A}$ , $R_{GE} = 3.3 \Omega$ , $V_{GE} = 15 \text{ V}$ $T_j = 125^\circ\text{C}$ (see Figure 18)		60 170 77 1400 2040		ns ns ns $\mu\text{J}$ $\mu\text{J}$

(3) Turn-off losses include also the tail of the collector current.

Figure 3: Output Characteristics

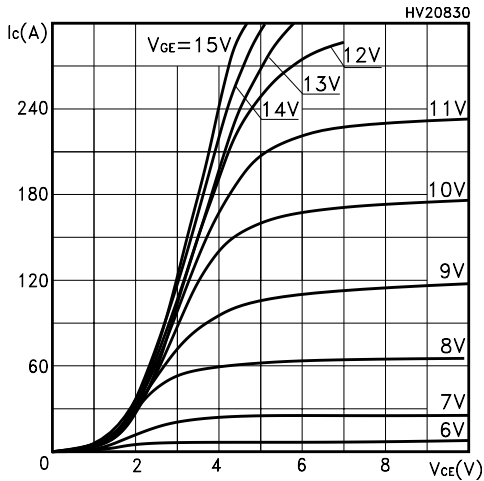

Figure 4: Transconductance

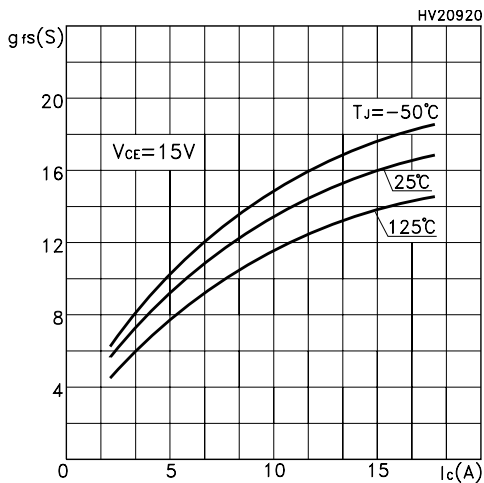

Figure 5: Collector-Emitter On Voltage vs Collector Current

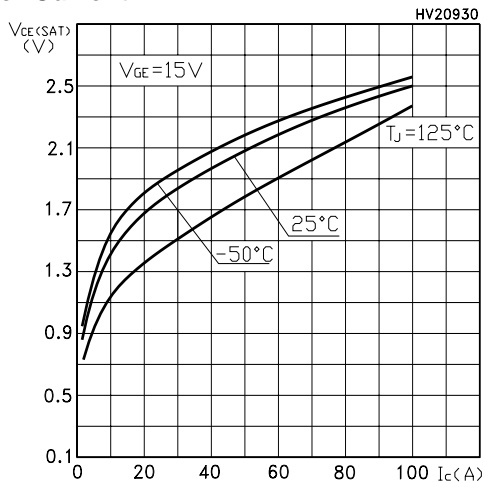

Figure 6: Transfer Characteristics

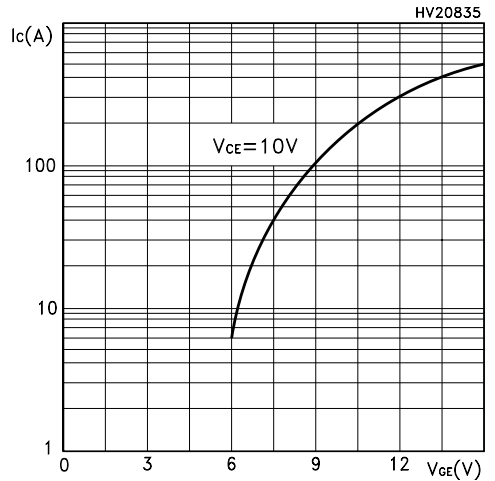

Figure 7: Collector-Emitter On Voltage vs Temperature

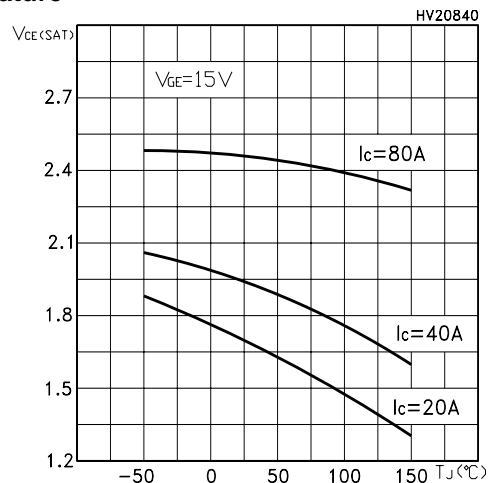
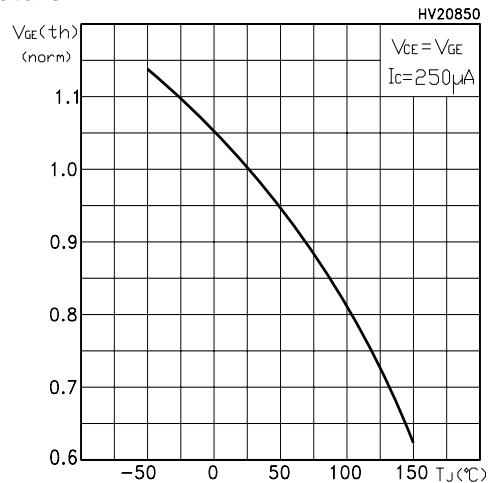
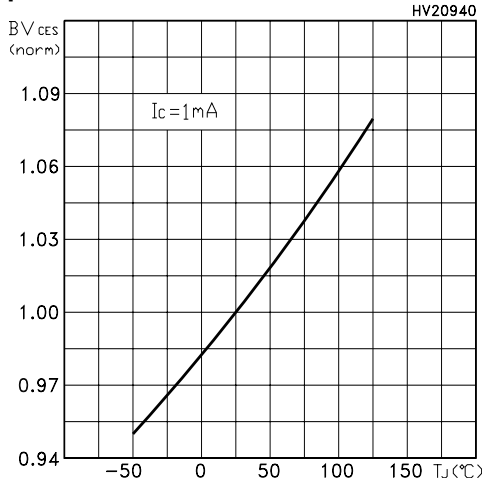

Figure 8: Normalized Gate Threshold vs Temperature



**Figure 9: Normalized Breakdown Voltage vs Temperature**



**Figure 10: Capacitance Variations**

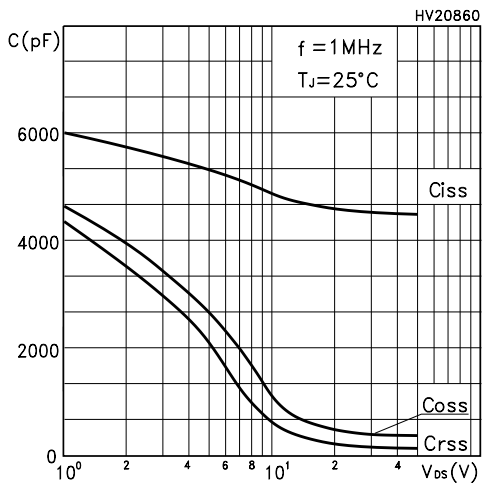

**Figure 11: Total Switching Losses vs Gate Resistance**

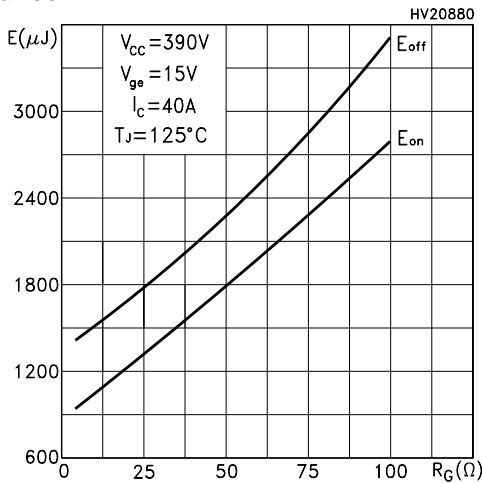

**Figure 12: Gate Charge vs Gate-Emitter Voltage**

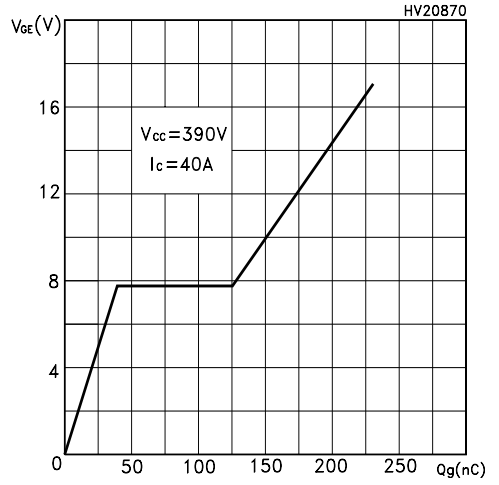

**Figure 13: Total Switching Losses vs Temperature**

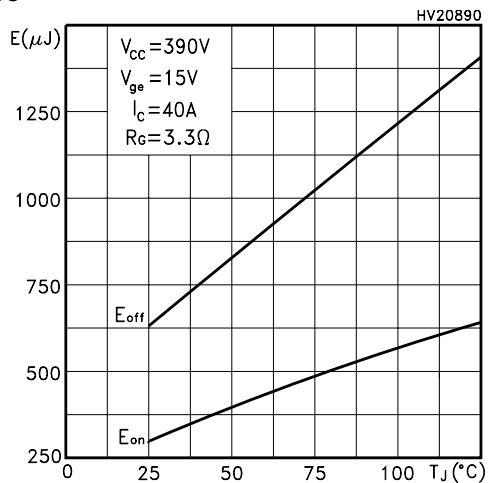

**Figure 14: Total Switching Losses vs Collector Current**

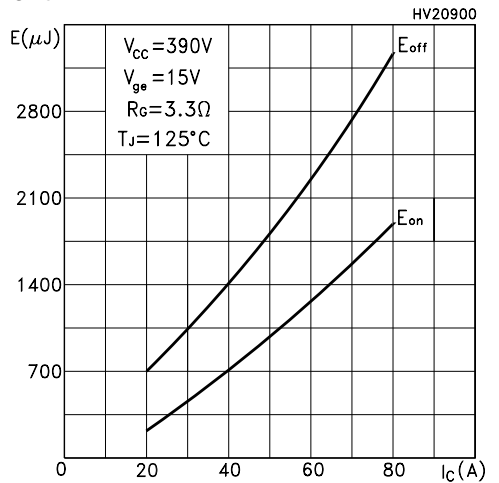

Figure 15: Thermal Impedance

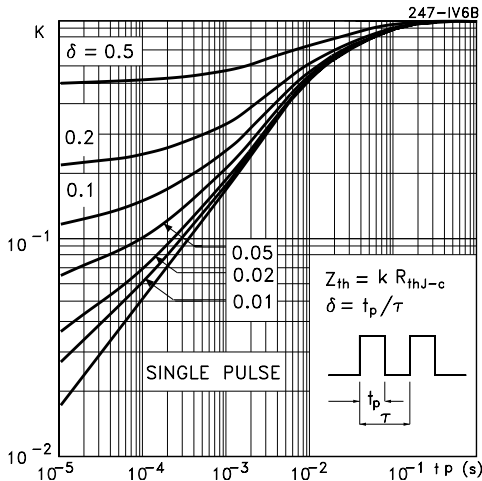

Figure 16: Turn-Off SOA

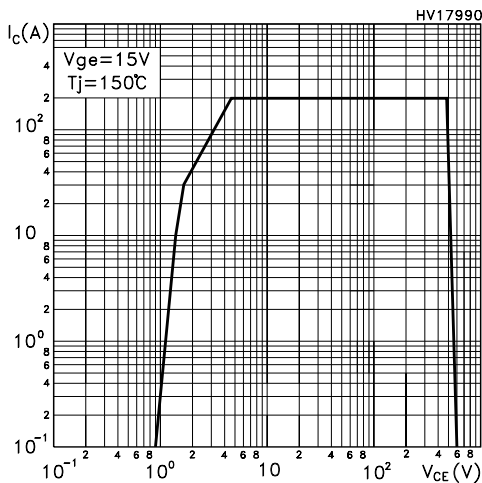
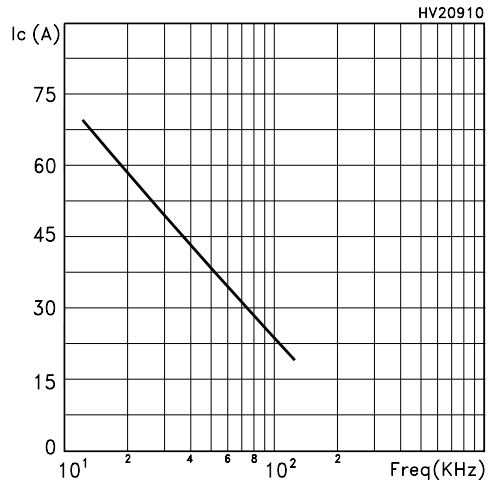

Figure 17: Ic vs Frequency



For a fast IGBT suitable for high frequency applications, the typical collector current vs. maximum operating frequency curve is reported. That frequency is defined as follows:

$$f_{MAX} = (P_D - P_C) / (E_{ON} + E_{OFF})$$

1) The maximum power dissipation is limited by maximum junction to case thermal resistance:

$$P_D = \Delta T / R_{THJ-C}$$

considering  $\Delta T = T_J - T_C = 125^\circ C - 75^\circ C = 50^\circ C$

2) The conduction losses are:

$$P_C = I_c * V_{CE(SAT)} * \delta$$

with 50% of duty cycle,  $V_{CESAT}$  typical value @  $125^\circ C$ .

3) Power dissipation during ON & OFF commutations is due to the switching frequency:

$$P_{SW} = (E_{ON} + E_{OFF}) * freq.$$

4) Typical values @  $125^\circ C$  for switching losses are used (test conditions:  $V_{CE} = 390V$ ,  $V_{GE} = 15V$ ,  $R_G = 3.3 \text{ Ohm}$ ). Furthermore, diode recovery energy is included in the  $E_{ON}$  (see note 2), while the tail of the collector current is included in the  $E_{OFF}$  measurements (see note 3).

Figure 18: Test Circuit for Inductive Load Switching

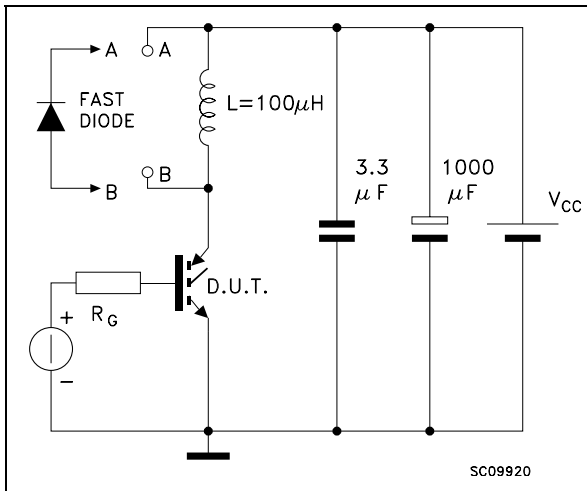

Figure 19: Switching Waveforms

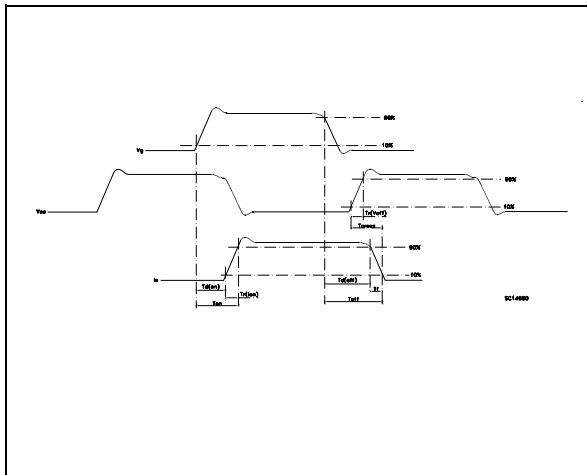
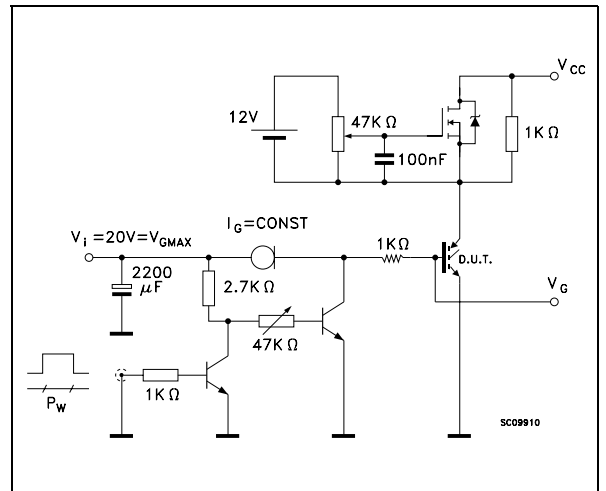
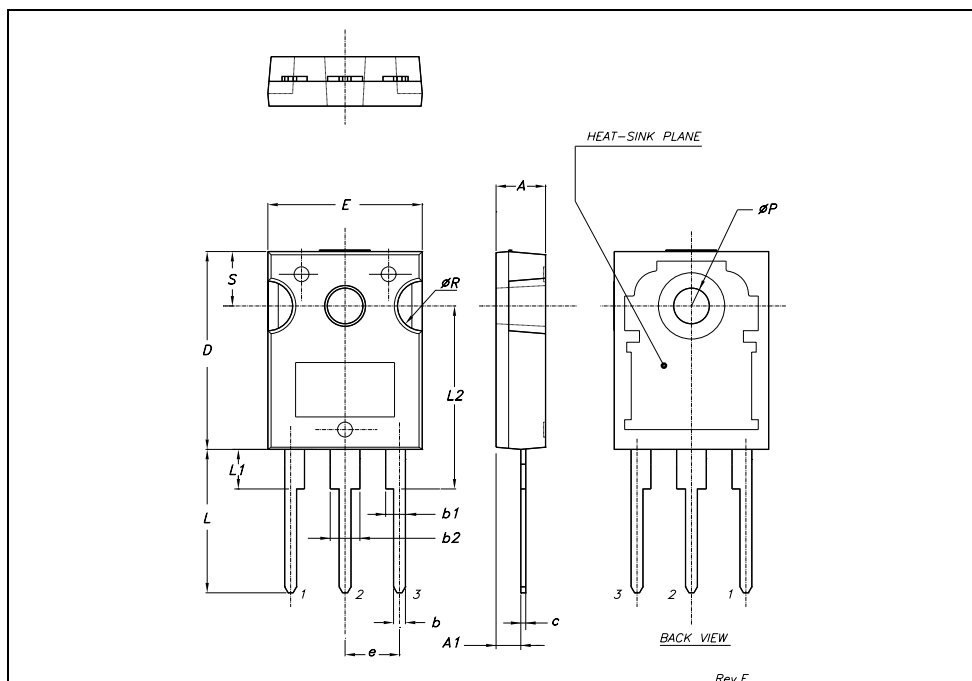

Figure 20: Gate Charge Test Circuit



## TO-247 MECHANICAL DATA

DIM.	mm.			inch		
	MIN.	TYP.	MAX.	MIN.	TYP.	MAX.
A	4.85		5.15	0.19		0.20
A1	2.20		2.60	0.086		0.102
b	1.0		1.40	0.039		0.055
b1	2.0		2.40	0.079		0.094
b2	3.0		3.40	0.118		0.134
c	0.40		0.80	0.015		0.03
D	19.85		20.15	0.781		0.793
E	15.45		15.75	0.608		0.620
e		5.45			0.214	
L	14.20		14.80	0.560		0.582
L1	3.70		4.30	0.14		0.17
L2		18.50			0.728	
øP	3.55		3.65	0.140		0.143
øR	4.50		5.50	0.177		0.216
S		5.50			0.216	





**Table 10: Revision History**

Date	Revision	Description of Changes
13-Jul-2004	9	Stylesheet update. No content change
14-Jul-2004	10	Some datas have been updated

Information furnished is believed to be accurate and reliable. However, STMicroelectronics assumes no responsibility for the consequences of use of such information nor for any infringement of patents or other rights of third parties which may result from its use. No license is granted by implication or otherwise under any patent or patent rights of STMicroelectronics. Specifications mentioned in this publication are subject to change without notice. This publication supersedes and replaces all information previously supplied. STMicroelectronics products are not authorized for use as critical components in life support devices or systems without express written approval of STMicroelectronics.

The ST logo is a registered trademark of STMicroelectronics  
All other names are the property of their respective owners

© 2004 STMicroelectronics - All Rights Reserved  
STMicroelectronics GROUP OF COMPANIES

Australia - Belgium - Brazil - Canada - China - Czech Republic - Finland - France - Germany - Hong Kong - India - Israel - Italy - Japan - Malaysia - Malta - Morocco - Singapore - Spain - Sweden - Switzerland - United Kingdom - United States.