

DATE	DESCRIPTION	REV.
9.17.04	CHANGE AS PER ECN 04-109	D
7.28.08	CHANGE AS PER ECN 08-133	E
7.05.11	CHANGE AS PER ECN 11-091 SPLIT C/M TO 'C' AND 'M'	F
8.15.11	CHANGE AS PER ECN 11-106	G

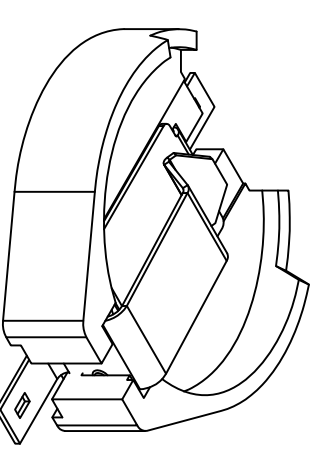
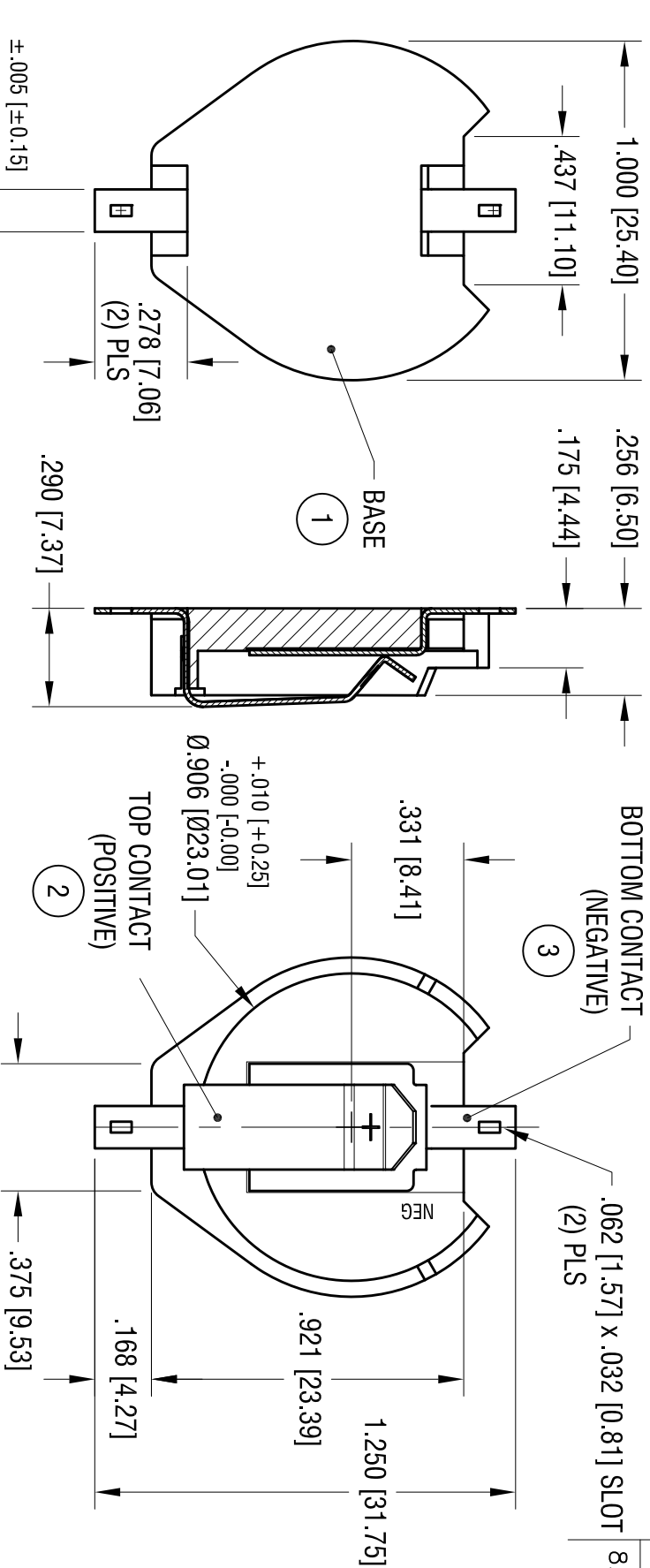

THIS DOCUMENT IS THE PROPERTY OF
KEYSTONE ELECTRONICS CORP.
AND
SHALL NOT BE REPRODUCED, DISTRIBUTED
OR USED AS A BASIS FOR MANUFACTURE
WITHOUT PRIOR WRITTEN PERMISSION
FROM KEYSTONE ELECTRONICS CORP.

KEYSTONE ELECTRONICS CORP.
www.keystec.com • ASTORIA, N.Y. 11105-2017 • Tel (718) 956-8900

PART NAME
23mm BATTERY HOLDER, SMT

MATERIAL
AS NOTED

FINISH
AS NOTED

TOLERANCES	INCH	[MM]	CODE	DWG NO.
DECIMAL	± .010	[± 0.25]	C	1073
ANGULAR	± 1°			
UNLESS OTHERWISE SPECIFIED				

ITEM	DESCRIPTION	MATERIAL/FINISH
1	BASE BLACK	HIGH TEMPERATURE NYLON (UL 94V-0)
2	TOP CONTACT	SPRING STEEL .015 [0.38] THK
3	BOTTOM CONTACT	TIN NICKEL PLATE

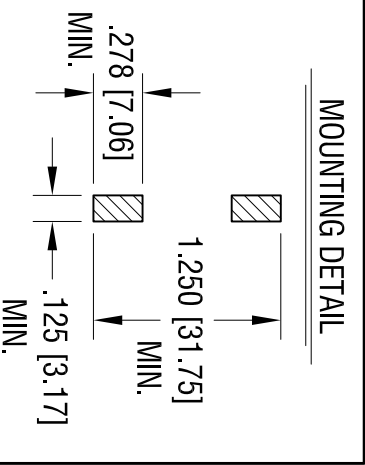

MOUNTING DETAIL