

| ITEM | DESC.         | MATERIAL              | REMARKS                                  |
|------|---------------|-----------------------|--|
| 5    | OUT SHELL     | STEEL                 | OVER-PLATING: Ni 80~200u"                |
| 4    | PLASTIC PARTS | LCP UL94V-0           | 30% G/F ,Blue                            |
| 3    | SHELL         | STAINLESS STEEL 201   | OVER-PLATING: Ni 40u"                    |
| 2    | 4P TERMINAL   | PHOSPHOR BRONZE C5191 | CONTACT AREA:30u"<br>SOLDER AREA:Sn 80u" |
| 1    | 5P TERMINAL   | BRASS C2680           | UNDER-PLATING: Ni 50u"                   |

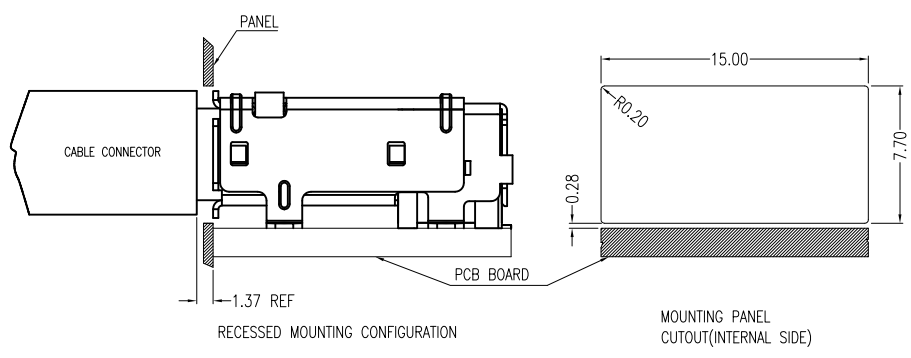
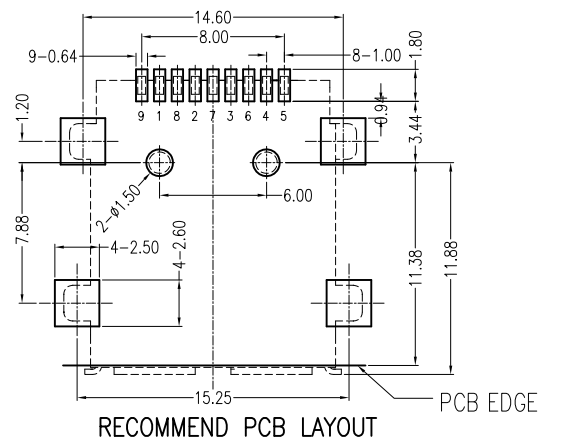
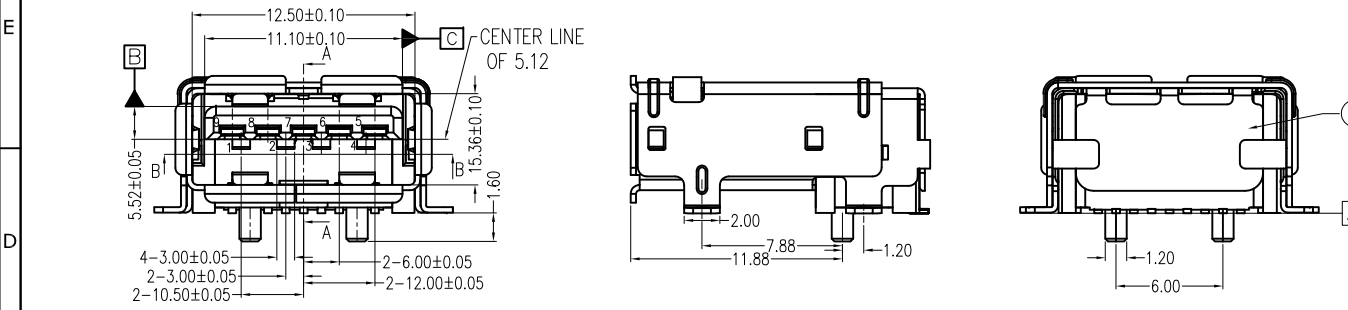

| Pin Assignments |             |
|-----------------|-------------|
| Pin No.         | Signal Name |
| 1               | VBUS        |
| 2               | D-          |
| 3               | D+          |
| 4               | GND         |
| 5               | StdA_SSRX-  |
| 6               | StdA_SSRX+  |
| 7               | GND_DRAIN   |
| 8               | StdA_SSTX-  |
| 9               | StdA_SSTX+  |
| Shell           | Shield      |

| Product Number | Description  |
|----------------|--|
| 209B-SG01      | USB3.0 A Receptacle, SMT Type ,Contact:30u" Gold Plating |

| UNLESS OTHERWISE SPECIFIED TOLERANCE |          |            |
|--------------------------------------|----------|------------|
| ANGLES                               | ANG.     | ±5°        |
| LINEAR                               | 0.       | ±0.3       |
|                                      | 0.0      | ±0.25      |
|                                      | 0.00     | ±0.20      |
| SCALE                                | AS SHOWN | UNIT: mm   |
| DRAWN                                | Willis   | 2013/03/12 |
| CHECKED                              | Angel    | 2013/03/12 |
| APPROVED                             | Ken      | 2013/03/12 |

**ATTEND**  
www.attend.com.tw  
DRAWN NAME: USB 3.0 A Receptacle SMT Type  
PRODUCT NO. 209B-SG01  
FILE NAME 209B-SG01\_B\_3

| REV. | DESCRIPTION | DATE | REV. | DESCRIPTION | DATE |
|------|-------------|------|------|-------------|------|
| 1    |             |      | 4    |             |      |
| 2    |             |      | 5    |             |      |
| 3    |             |      | 6    |             |      |
| 4    |             |      | 7    |             |      |

Revise:  
Revise:  
Revise:



SIZE A4  
REV. 1.0