

Arduino MC60(E) GSM/GPRS/GNSS/BLE Shield

The Arduino MC60(E) GSM/GPRS/GNSS/BLE Shield is a helpful tool for those advanced hobbyists and professionals, who want to get familiar with GSM/GPRS/GNSS/BLE data/voice communication using their Arduino board. With a powerful MC60(E) module from Quectel users are able to use this shield in many different applications. Please read the MC60(E) Hardware design and MC60 AT Command Set documentation first. MC60E documentation download <http://www.quectel.com/qdownload/mc60.html>

1. Hardware Requirements:

- valid micro SIM card
- Arduino UNO (ATMega 328P), Mega (Atmega2560) or compatible board

2. Technical requirements

- Operating voltage range: 6-12VDC
- Operating current: up to 2A DC during transmission bursts, make sure your power supply is sufficient for powering GSM module during these bursts

3. GSM/GPRS/GNSS/BLE module:

- MC60 QUECTEL documentation:
<http://www.quectel.com/qdownload/mc60.html>
- RF connector – SMA female, telematic antenna is part of delivery, any GSM antenna with SMA connector can be used

4. Arduino MC60(E) Shield description

- LEDs: Red LED – Network Light

permanently OFF	MC60 module is OFF
64 ms ON / 800 ms OFF	MC60 is not logged in the network
64 ms ON / 2000 ms OFF	MC60 is logged in the network
64 ms ON / 600 ms OFF	Ongoing GPRS data transfer

- Green LED: Shield Powered
- Yellow LED: 1PPS (1 Pulse Per Second)

5. Connectors on MC60 Shield:

Conn J1 (POWER)	Signal
PIN1	No connection
PIN2	No connection
PIN3	5VDC from Arduino board
PIN4	GND
PIN5	GND
PIN6	VIN – 6-12VDC from external power source

Conn J2 (ANALOG)	Signal
PIN1	No connection
PIN2	No connection
PIN3	No connection
PIN4	No connection
PIN5	No connection
PIN6	No connection

Conn J3 (Digital8_13)	Signal
PIN1	PWRKEY (default)
PIN2	No connection
PIN3	GSMON (must be HIGH to enable communication with MC60)
PIN4	No connection
PIN5	No connection
PIN6	No connection
PIN7	GND
PIN8	No connection

Conn J4 (Digital0_7)	Signal
PIN1	D0_RX (Arduino ---> MC60 Shield) default

PIN2	D1_TX (MC60 Shield ---> Arduino) default
PIN3	D2 (Alternative SW RX)
PIN4	D3 (Alternative SW TX)
PIN5	DETECT (uSD card presence detection)
PIN6	RI (Ring Indicator)
PIN7	No connection
PIN8	ENABLE (Could be used to switch VREG input ON/OFF)

Component placement and board overview:

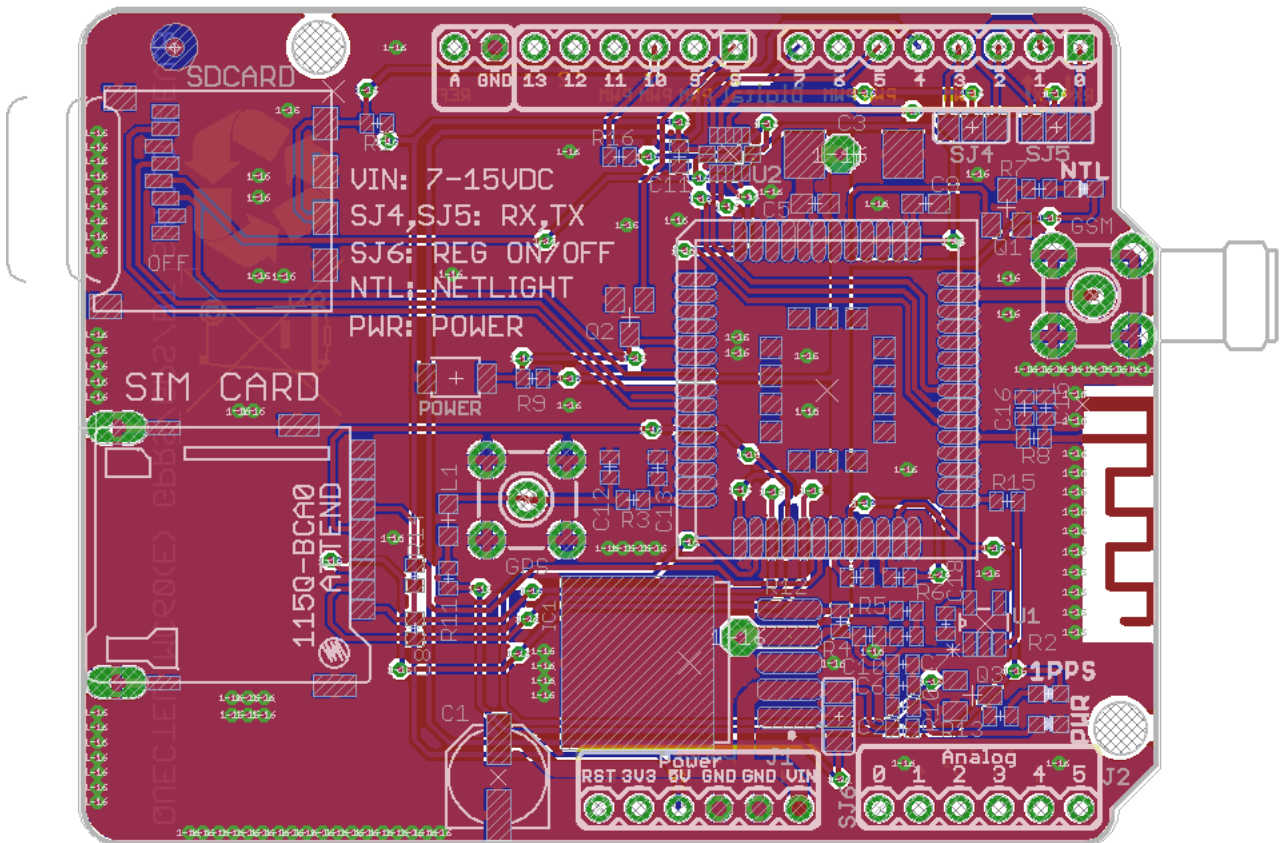

BOM list:

Part	Value	Device	Package	Description
ANT1	ANTENNA GSM	ANTENNA GSM	2J0104	
ANT2	ANTENNA GPS	ANTENNA GPS	2J450GMP	
C1	100uF 25V	CPOL-EUD	PANASONIC_D	POLARIZED CAPACITOR, European symbol
C2	100nF	CAP0402	C0402	Capacitor
C3	100uF	CPOL-EUSMCD	SMC_D	POLARIZED CAPACITOR, European symbol
C5	2u2	C-EUC0603	C0603	CAPACITOR, European symbol
C6	10pF	CAP0402	C0402	Capacitor
C7	33pF	CAP0402	C0402	Capacitor
C8	220nF	CAP0402	C0402	Capacitor
C9	4u7	C-EUC0603	C0603	CAPACITOR, European symbol
C10	100nF	CAP0402	C0402	Capacitor
C11	100nF	CAP0402	C0402	Capacitor

C12	DNM	C-EUC0402	C0402	CAPACITOR, European symbol
C13	DNM	C-EUC0402	C0402	CAPACITOR, European symbol
C15	DNM	C-EUC0402	C0402	CAPACITOR, European symbol
C16	DNM	C-EUC0402	C0402	CAPACITOR, European symbol
C18	1uF	CAP0402	C0402	Capacitor
GPS	LTI-SASF54GT	LTI-SASF54GT	LTI-SASF54GT	SMA vertical PCB thru hole jack
GSM	BU-SMA-H	BU-SMA-H	BU-SMA-H	FEMALE SMA CONNECTOR
IC1	MIC29302W	MIC29302W	DPAK171P1524X485-6N	
J1	Power	M06SIP	1X06	Header 6
J2	Analog	M06SIP	1X06	Header 6
J3	Digital_8_13	M08	1X08	Header 8
J4	Digital_0_7	M08	1X08	Header 8
L1	47nH	L-EUL2012C	L2012C	INDUCTOR, European symbol
LED1	1PPS	LED0603	LED-0603	LEDs
LED3	NETLIGHT/RED	LED0603	LED-0603	LEDs
LED4	PWR/GRN	LED0603	LED-0603	LEDs
M1	MC60	MC60	MC60	QUECTEL MC60E
POWER		SMD-BUTTON(2P-3.0X2.5X1.2+0.4MM)	SW2-2.6-3.0X2.5X1.2+0.4MM	311020047
Q1	MM105	MMBTRC105	SOT23	NPN Transistor
Q2	MM105	MMBTRC105	SOT23	NPN Transistor
Q3	MM105	MMBTRC105	SOT23	NPN Transistor
R1	100k	RESISTOR0402	C0402	Resistor
R2	10k	RESISTOR0402	C0402	Resistor
R3	0R	R-EU_R0402	R0402	RESISTOR, European symbol
R4	100k	RESISTOR0402	C0402	Resistor
R5	33k	RESISTOR0402	C0402	Resistor
R6	0R	R-EU_R0402	R0402	RESISTOR, European symbol
R7	1K	RESISTOR0402	C0402	Resistor
R8	0R	R-EU_R0402	R0402	RESISTOR, European symbol
R9	4k7	RESISTOR0402	C0402	Resistor
R10	1K	RESISTOR0402	C0402	Resistor
R11	10R	RESISTOR0402	C0402	Resistor
R12	0R	R-EU_R0402	R0402	RESISTOR, European symbol
R13	1K	RESISTOR0402	C0402	Resistor
R14	100k	RESISTOR0402	C0402	Resistor
R15	10K	RESISTOR0402	C0402	Resistor
R16	1k	RESISTOR0402	C0402	Resistor
SDCARD	MICROSD	MICROSD	MICROSD	Micro-SD / Transflash card holder
U\$1	MICROSIM	MICROSIM	MICROSIM	ATTEND 11
U\$5	FIDUCIAL1X2.5	FIDUCIAL1X2.5	FIDUCIAL-1X2.5	Fiducial Alignment Points
U1	TLV70033DDCT	TLV70033DDCT	SOT95P280X110-5N	200-mA, Low-IQ, Low-Dropout Regulator
U2	NTS0104BQ	NTS0104BQ	QFN50PX250X300X100-15N	

Schematic diagram

QUECTEL MC60 ARDUINO SHIELD 2018

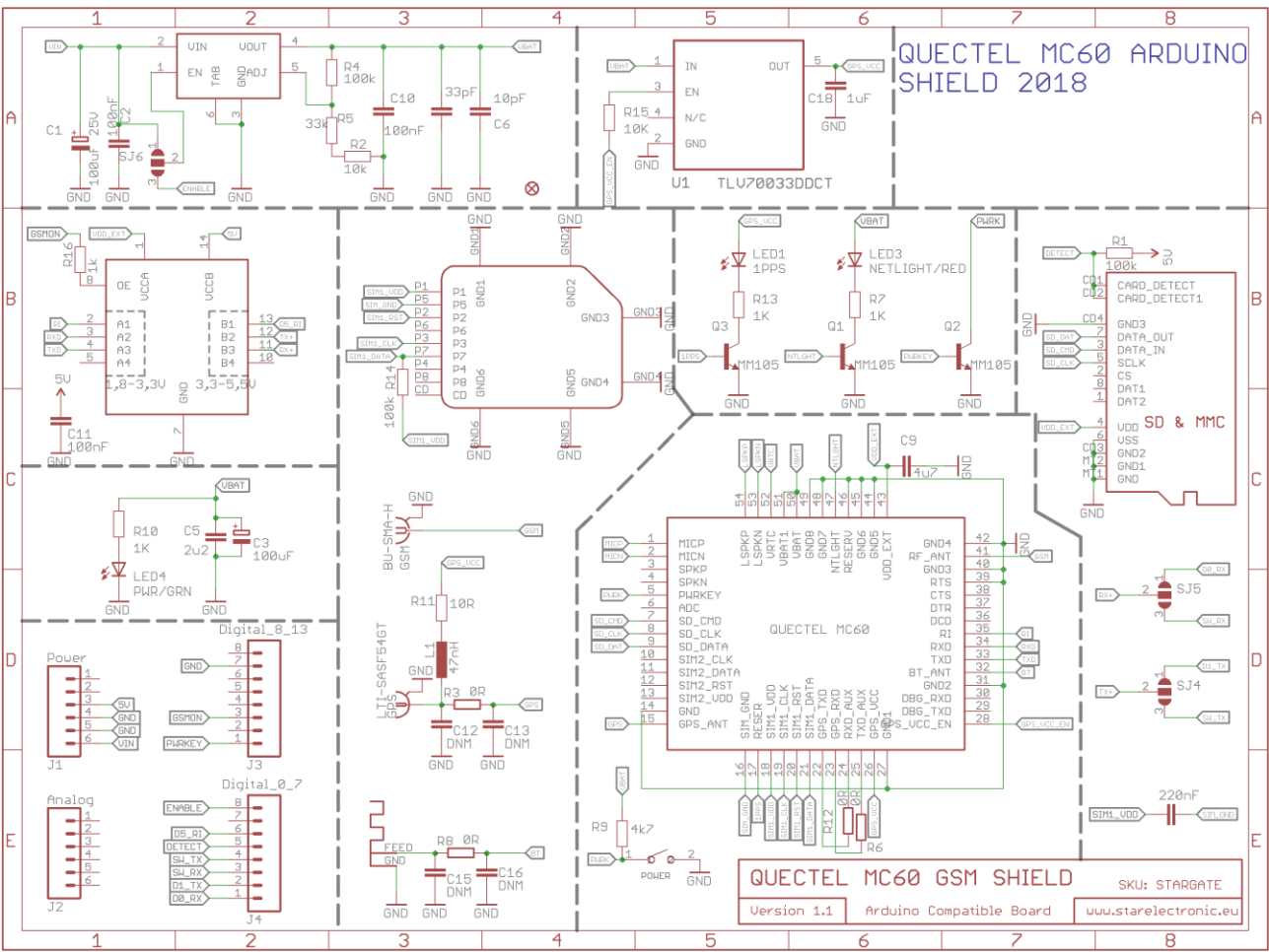

QUECTEL MC60 GSM SHIELD SKU: STARGATE
 Version 1.1 Arduino Compatible Board www.starelectronic.eu