

THIS DOCUMENT IS THE PROPERTY OF
KEYSTONE ELECTRONICS CORP. AND
SHALL NOT BE REPRODUCED, DISTRIBUTED
OR USED AS A BASIS FOR MANUFACTURE
WITHOUT PRIOR WRITTEN PERMISSION
FROM KEYSTONE ELECTRONICS CORP.

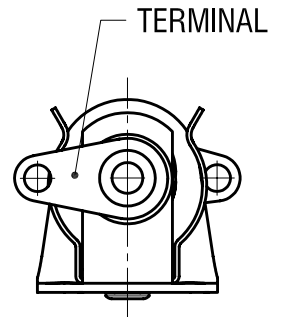
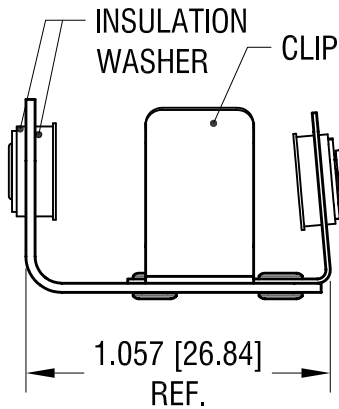
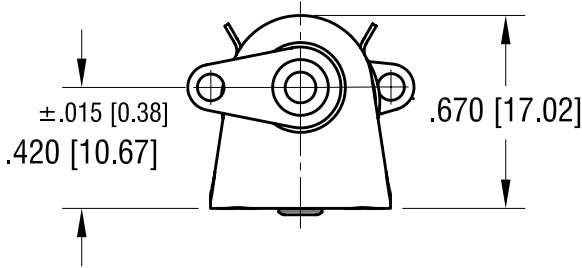
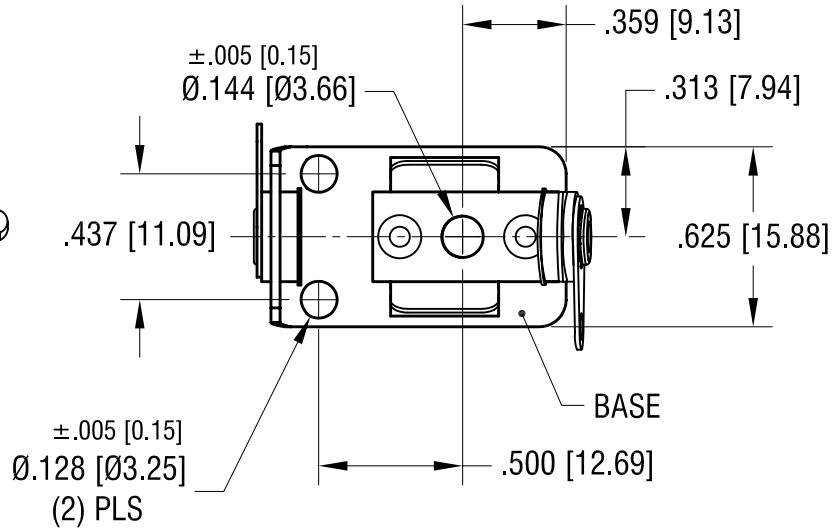
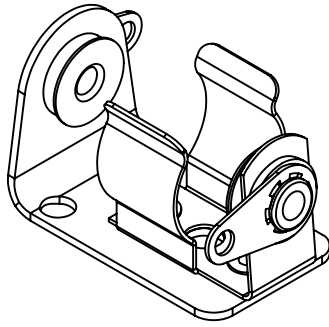

NOTE:
 BASE: MAT'L- C.R.S. .032 [0.81] TH'K
 FINISH- NICKEL PLATE
 CLIP: MAT'L- .015 [0.38] TH'K ANNEALED SPRING STEEL
 FINISH- NICKEL PLATE
 EYELET: MAT'L- BRASS
 FINISH- TIN PLATE
 TERMINAL: BRASS .016 [0.40] TH'K
 FINISH- TIN PLATE

KEYSTONE ELECTRONICS CORP.			
www.keyelco.com • ASTORIA, N.Y. 11105-2017 • Tel (718) 956-8900			
PART NAME		BATTERY HOLDER	
MATERIAL		AS NOTED	
FINISH		DRN BY	DATE
AS NOTED		NT	12.10.08
		APP'D	SCALE
		LN	1.5X
TOLERANCES	INCH [MM]	CODE	DWG NO.
DECIMAL	± .010 [± 0.25]	C	1105
ANGULAR	± 1°		
UNLESS OTHERWISE SPECIFIED			

DATE	DESCRIPTION	REV.	
------	-------------	------	--