

**BOLYMIN**

**SPECIFICATIONS FOR  
LCD MODULE**

MODEL NO.  
BO9864BFPHH252j\$  
VER.01

**ROHS**  
COMPLIANT

FOR MESSRS:

---

ON DATE OF:

---

APPROVED BY:

---

**BOLYMIN, INC.**

5F, No. 38, Keya Rd., Daya Dist., Central Taiwan Science Park, Taichung City, 42881, Taiwan.

Web Site: <http://www.bolymin.com.tw> TEL:+886-4-25658689 FAX:+886-4-25658698

### History of Version

Version	Contents	Date	Note
01	NEW VERSION	2016/08/24	SPEC.

## CONTENTS

1. Numbering System
2. Handling Precaution
3. General Specification
4. Absolute Maximum Rating
5. Electrical Characteristics
6. Optical Characteristics
7. Interface Pin Function
8. Block Diagram And Power Supply for LCD Module
9. Backlight information
10. Quality Assurance
11. Reliability
12. Appendix (Drawing , ST7548i controller data)
  - 12-1 Drawing
  - 12-2 ST7548T controller data

## 1. Numbering System

<u>B</u>	<u>O</u>	<u>9864</u>	<u>B</u>	<u>F</u>	<u>P</u>	<u>H</u>	<u>-</u>	<u>H</u>	<u>252j\$</u>
0	1	2	3	4	5	6	7	8	9

<b>0</b>	Brand	Bolymin	
<b>1</b>	Module Type	C= character type G= graphic type P= TAB/TCP type	O= COG type F= COF type L=PLED/OLED
<b>2</b>	Format	2002=20 characters, 2 lines 12232= 122 x 32 dots	
<b>3</b>	Version No.	A type	
<b>4</b>	LCD Color	G=STN/gray Y=STN/yellow-green PLED/yellow-green C=color STN,OLED/RGB	B=STN/blue,OLED/blue F=FSTN T=TN
<b>5</b>	LCD Type	R=positive/reflective P=positive/transflective	M=positive/transmissive N=negative/transmissive
<b>6</b>	Backlight type/color	L=LED array/ yellow-green H=LED edge/white R=LED array/red G=LED edge/yellow-green F=RGB array I=RGB edge Q=LED edge/red N=No backlight	D=LED edge/blue E=EL/white B=EL/blue C=CCFL/white Y=LED Bottom/yellow O=LED array/orange K=LED edge/green A=LED edge/amber
<b>7</b>	CGRAM Font (applied only on character type)	J=English/Japanese Font E=English/European Font G=Chinese(simple) F=Chinese(traditional)	C=English/Cyrillic Font H=English/Hebrew Font A=English/Arabic Font
<b>8</b>	View Angle/ Operating Temperature	B=Bottom/Normal Temperature H=Bottom/Wide Temperature U=Bottom/Ultra wide Temperature	T=Top/Normal Temperature W=Top/Wide Temperature C=9H/Normal Temperature E=Top/ultra wide temperature
<b>9</b>	Special Code	3=3.3 volt logic power supply n=negative voltage for LCD c=cable/connector 252j= Bottom contact	t=temperature compensation for LCD p=touch panel \$=RoHS

## 2. Handling Precaution

### 2.1 Precaution in use of LCD Module

- 2.1.1. LCD panel is made of glass. Avoid excessive mechanical shock or applying strong pressure and/or sharp tools on the surface of display area.
- 2.1.2. The polarizer placed on the display surface is easily scratched and damaged. Extreme care should be taken when handling it. To clean dust or dirt off the display surface, wipe gently with cotton, or other soft material soaked with isopropyl alcohol, ethyl alcohol, do not use water, ketone or aromatics to clear display surface, and never scrub it hard.
- 2.1.3. Keep LCD panels away from direct sunlight. The storage environment should be dust-free, clean, dry, temperature is  $25^{\circ}\text{C} \pm 10^{\circ}\text{C}$  and the humidity is below 55% RH.
- 2.1.4. Do not input any signal before power is turned on.
- 2.1.5. Avoid pressing on the metal bezel, otherwise the elastomer connector could be deformed and lose contact, resulting in missing pixels and also cause rainbow on the display.
- 2.1.6. It's important to control soldering temperature and time. RoHS compliant materials might need higher temperature and time, but try to keep temperature under  $350^{\circ}\text{C}$  and time in 3-5 sec.
- 2.1.7. EL is manufactured from the organic film, and is easily affected by temperature, humidity and other environmental impact. Long time storage might cause low quality of the case. Therefore, please start production in 3 months after reception of the LCM. If in any case, long time storage over 3 months is necessary, please keep EL in vacuum package or at least in humidity  $< 35\%$  RH, and temperature  $25^{\circ}\text{C} \pm 10^{\circ}\text{C}$ .  
Note: 2.1.7. is applied to EL backlight only.

### 2.2 Static Electricity Precautions:

- 2.2.1. The LCD module contains a C-MOS LSI. People who operate the LCM should wear ESD protection equipment to prevent ESD hurt on products.
- 2.2.2. Do not touch any of the conductive parts such as the LSI pads; the copper leads on the PCB and the interface terminals with any parts of the human body.
- 2.2.3. Do not touch the connection terminals of the display with bare hand; it will cause disconnection or defective insulation of terminals.
- 2.2.4. The modules should be kept in anti-static bags or trays for storage.
- 2.2.5. Only properly grounded soldering irons should be used.
- 2.2.6. If an electric screwdriver is used, it should be grounded and shielded to prevent sparks.
- 2.2.7. The normal static prevention measures should be observed for work clothes and working benches.
- 2.2.8. Since dry air(almost low RH) is inductive to static, a humidity of 50-60% RH is recommended in assembly line.

### 2.3 Operation Precautions:

- 2.3.1. DC voltage applied on LCM causes electrochemical reactions, which will deteriorate the display over time. The applied pulse waveform should be a symmetric waveform such that no DC component remains. Be sure to use the specified operating voltage.
- 2.3.2. LCD driving voltage should be kept within specified range; excess voltage will shorten display life, while less voltage may not turn on LCM.
- 2.3.3. LCM response time will be extremely delayed in low operating temperature(such as  $-20^{\circ}\text{C}$ ) than in room operating temperature. Therefore, higher LCD driving voltage is required in low operating temperature; On the other hand, in high operating temperature (such as  $+70^{\circ}\text{C}$ ) LCD shows dark background color, therefore lower LCD driving voltage is required. Be sure to use the specified LCD driving voltage in different operating temperature.

## 2.4 Safety:

- 2.4.1 If the LCD panel breaks, be careful not to get the liquid crystal to touch your skin.  
If the liquid crystal touches your skin or clothes, please wash it off immediately by using soap and water.

## 2.5 WARRANTY POLICY

**Bolymin .Will provide one-year warranty for the products only if under specification operating conditions.**

**If there are functional defects found during the period of warranty, the defective products would be replaced on a one-to-one basis.**

**Bolymin would not be responsible for any direct/indirect liabilities consequential to any parties.**

## 2.6 MTBF

- 2.6.1 .By specific test condition, MTBF based on 30°C normal operation temperature is 50,000hours.

### 2.6.2 Test Condition:

2.6.2.1 Supply Voltage for LCM: Typical Vdd

2.6.2.2 CC (Constant Current) mode and typical current is applied for LED.

2.6.2.3 Run-Patterns: by Bolymin's test program that has defined patterns and cyclic period.

2.6.2.4 Humidity: 60%RH

### 2.6.3 Test Criteria:

Attenuation of average brightness:  $\leq 50\%$

Increasing of current consumption for LCM/Backlight:  $\leq 20\%$

Display function at room temperature: Normal

Appearance: Normal

### 3. General Specification

#### (1) Mechanical Dimension

Item	Standard Value	Unit
Number of dots	98 × 64	dots
Module Size (W x H x T)	36.2 x 34.0 x 4.0max-LED B/L	mm
View area	31.0(W) × 22.5(H)	mm
Dot size	0.26(W) × 0.31(H)	mm
Dot pitch	0.28(W) × 0.33(H)	mm
Size	1.5	inch

#### (2) Controller IC: ST7548i Controller

### 4. Absolute Maximum Ratings

#### 4.1 Electrical Absolute Maximum Ratings

(VSS=0V, Ta=25°C)

Item	Symbol	Min	Typ	Max	Unit
Supply Voltage For Logic	VDD-VSS	2.4	3.0	3.3	V
Supply Voltage For LCD	VLCD	0	—	13.5	V
Input Voltage	VI	-0.3	—	V <sub>DD</sub> +0.3	V

#### 4.2 Environmental Absolute Maximum Ratings

Item	Symbol	Min	Max	Unit	Note
Operating Temperature	TOP	-20	70	°C	(1)
Storage Temperature	TST	-30	80	°C	(1)

#### Note (1)

- (a) 90 %RH Max. (Ta ≤ 40 °C).
- (b) Wet-bulb temperature should be 39 °C Max. (Ta > 40 °C).
- (c) No condensation.

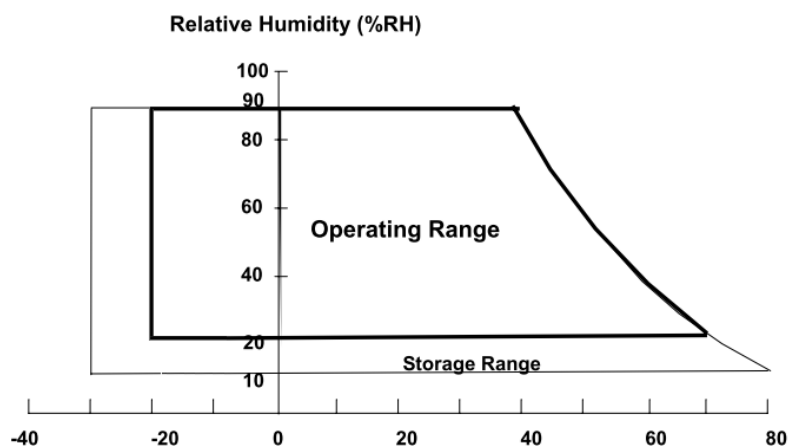

## 5. Electrical Characteristics

Parameter	Symbol	Condition	Min	Typ	Max	Unit
Logic Circuit Supply Voltage	VDD-VSS	--	2.8	3.0	3.3	V
LCD Driving Voltage	V <sub>LCD</sub>	25 °C	9.9	<b>10.2</b>	10.5	V
Input Voltage	V <sub>IH</sub>	--	0.7 VDD	--	VDD	V
	V <sub>IL</sub>	--	0	--	0.3 VDD	V
Logic Supply Current	I <sub>DD</sub>	VDD = 3.3V	--	2	--	mA
LCM Surface Luminance Ta=25°C	L	I <sub>LED</sub> =40 mA Display all OFF	67	100	—	cd/m <sup>2</sup>

※Optimum LCD driving voltage value, referring to above mentioned range, is changed due to different batch of LCD glass.

## 6. Optical Characteristics

a. FSTN

(Ta=25°C)

Item	Symbol	Min.	Typ.	Max.	Unit
View Angle (CR>=2)	$\theta_F$	-	36	-	deg
	$\theta_B$	-	38	-	deg
	$\varphi_L$	-	40	-	deg
	$\varphi_R$	-	45	-	deg
Contrast Ratio	CR	-	5	-	-
Response Time 25°C	T rise	-	200	400	ms
	T fall	-	250	400	ms

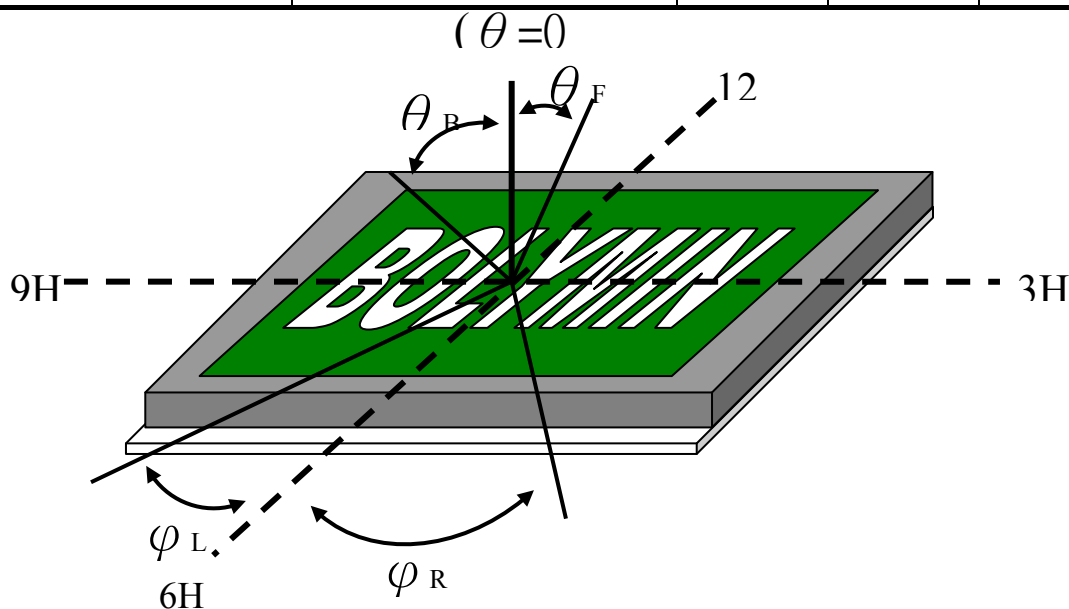



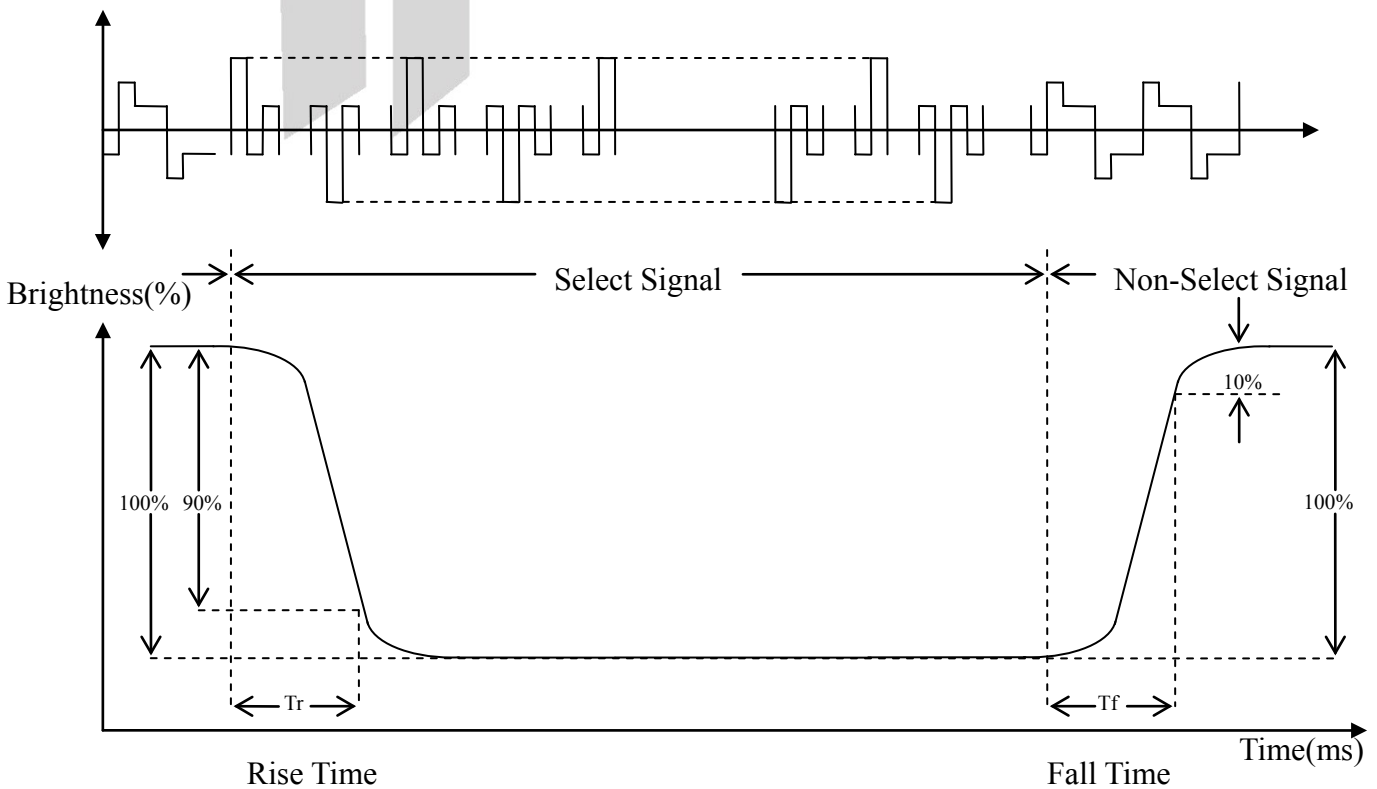
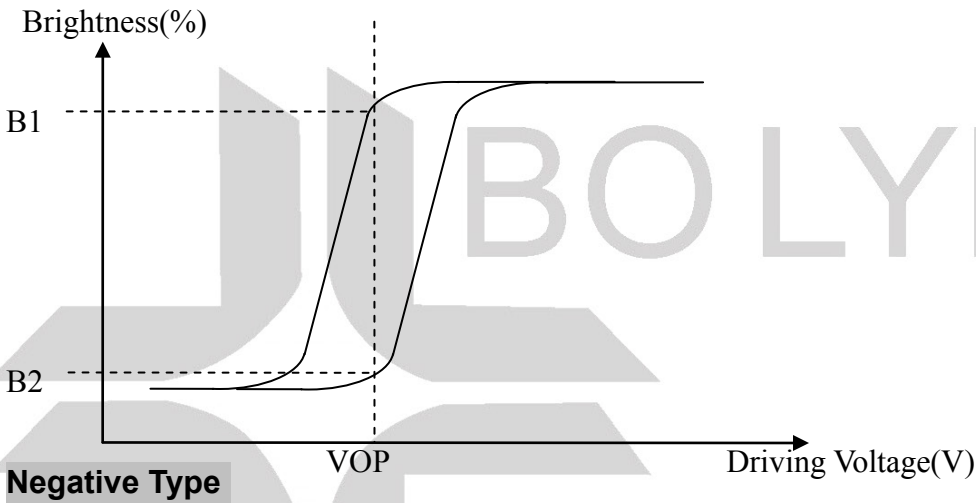
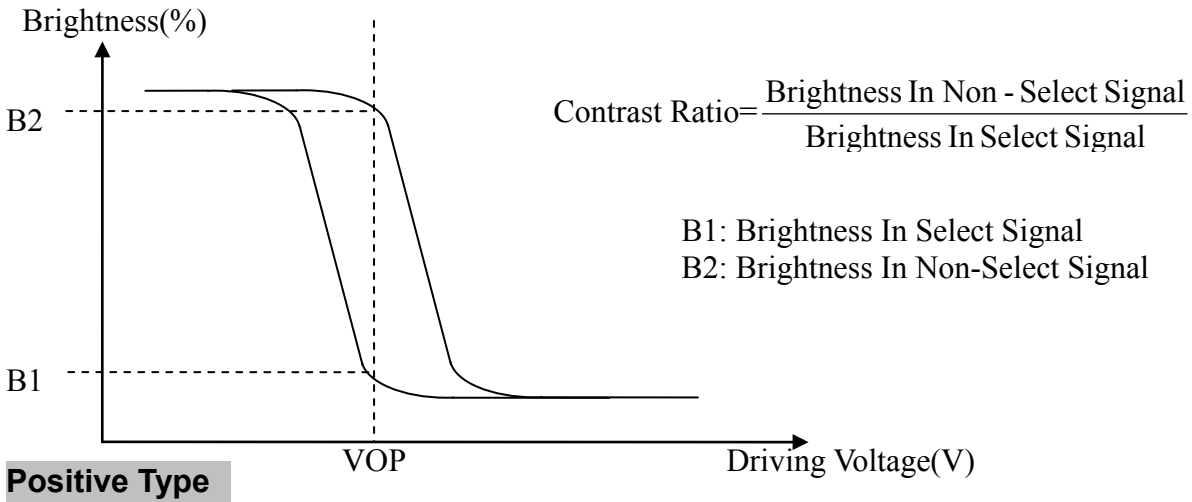

## 7.Interface Pin Function

No.	Symbol	Function
1	VLCD	LCD power supply
2	VSS1	Logic ground 0V
3	VSS2	Logic ground 0V
4	SCL	I <sup>2</sup> C-bus Serial clock signal input
5	SDA	I <sup>2</sup> C-bus data lines
6	RES	This signal is used to rest the device. This signal is active Low.
7	VDD2	Positive power supply
8	VDD1	Positive power supply

## 8. Block Diagram And Power Supply for LCD Module

Block Diagram

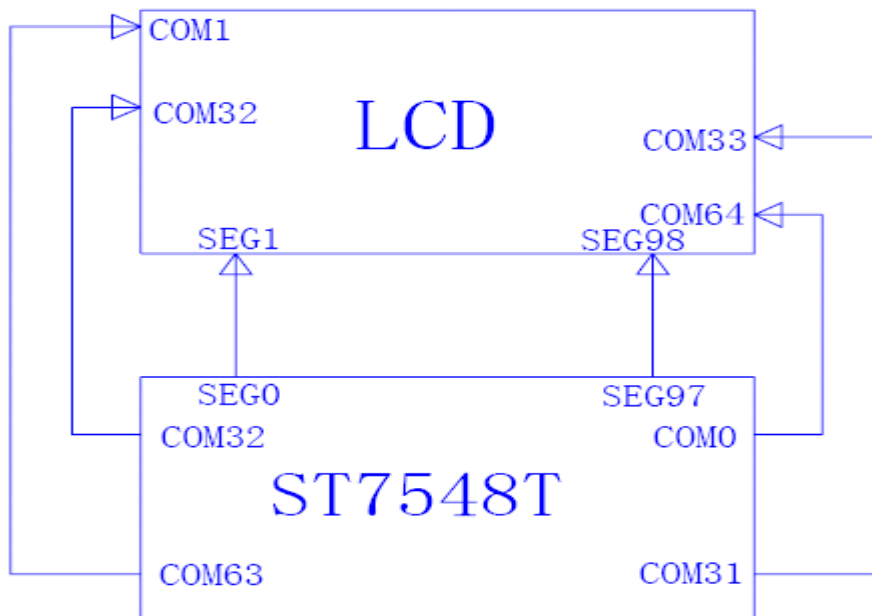

Display Configuration Setting :

MX=1 MY=0

Power Supply for LCD Module

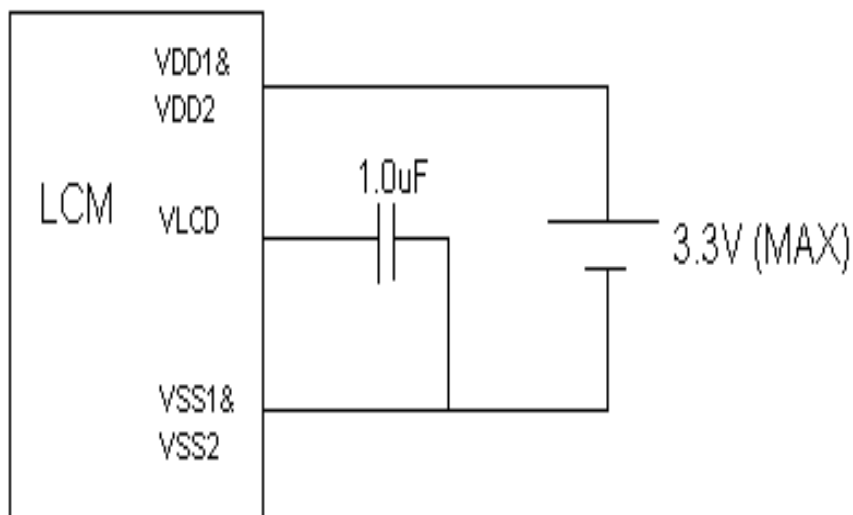

## 9. Backlight information

### 9.1 Specification

(1)LED edge/white

Parameter	Symbol	Min	Typ	Max	Unit	Test Condition
Supply Current	I <sub>LED</sub>	—	40	—	mA	V=3.1V
Supply Voltage	V <sub>f</sub>	—	3.1	3.4	V	I <sub>LED</sub> =40mA
Reverse Voltage	V <sub>R</sub>	—	—	5	V	
CIE	X	0.25		0.31		I <sub>LED</sub> =40mA
	Y	0.26	—	0.32		
Color	white					

### 9.2 Backlight driving methods

a.LED B/L drive from A · K

a.1 edge/ (white)

LCM

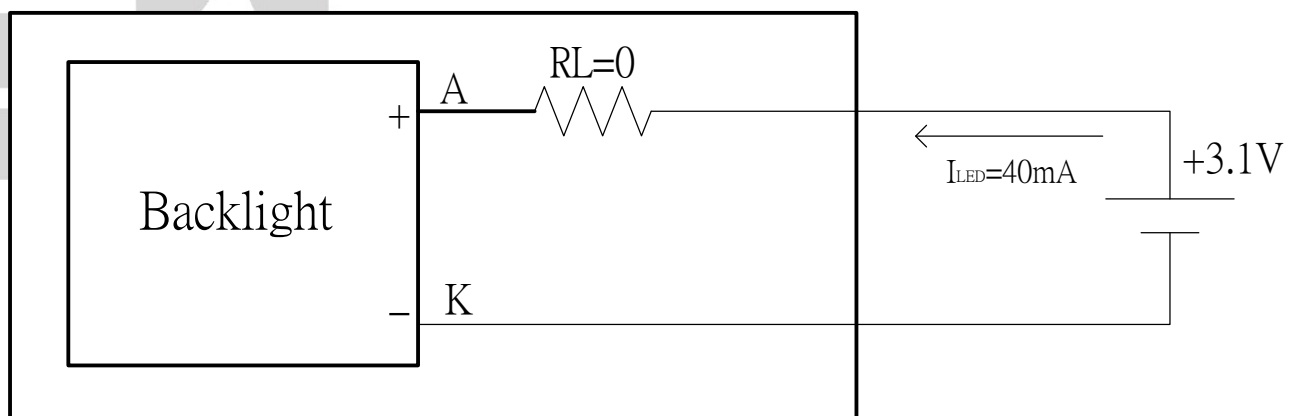

## 10. Quality Assurance

### 10.1 Inspection conditions

1. The LCD shall be inspected under 20~40W white fluorescent light.
2. Checking Direction shall be in the 40 degree from perpendicular line of specimen surface.
3. Checker shall see over 30 cm.
4. Inspect about 5 seconds for each side.
5. Defect that is located at outside of VA and doesn't affect function is ignored.

### 10.2 Inspection Parameters

NO.	Parameter	Criteria				
1	Black or White spots (Particle)	Zone		Acceptable Number	Class Of Defects	Acceptable Level
		Dimension				
		D ≤ 0.10		Disregard	Minor	2.5
		0.10 < D ≤ 0.2		4		
		0.2 < D ≤ 0.3		2		
0.3 < D		0				
D=(Long + Short)/2 Total defects should not exceed 5/module Defect that is located at outside of AA and doesn't affect function is ignored.						
2	Scratch, Substances	Zone		Acceptable Number	Class Of Defects	Acceptable Level
		X(mm)	Y(mm)			
		—	0.05 ≥ W	Disregard	Minor	2.5
		4.0 ≥ L	0.05 ≥ W	4		
		3.0 ≥ L	0.1 ≥ W	2		
—	0.1 < W	0				
X: Length    Y: Width Total defects should not exceed 5/module Defect that is located at outside of AA and doesn't affect function is ignored.						

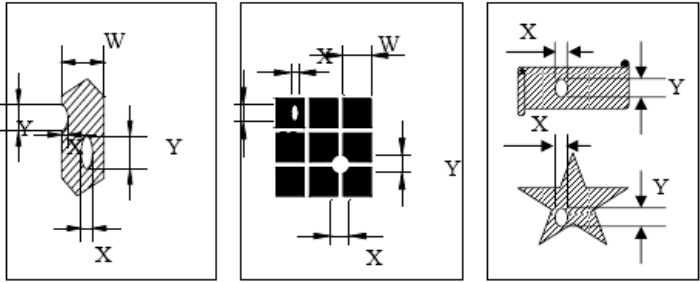
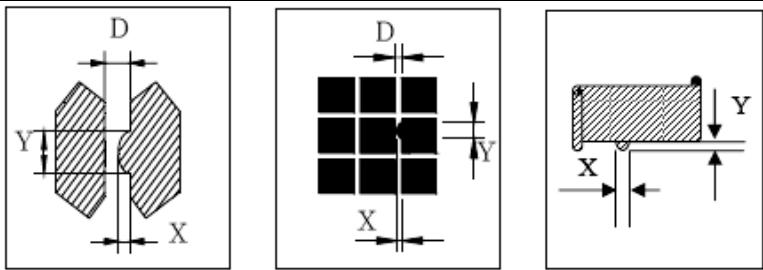
3	Air Bubbles ( between glass & polarizer)	<table border="1"> <tr> <th>Zone Dimension</th> <th>Acceptable Number</th> <th>Class Of Defects</th> <th>Acceptable Level</th> </tr> <tr> <td><math>D \leq 0.2</math></td> <td>Disregard</td> <td rowspan="3">Minor</td> <td rowspan="3">2.5</td> </tr> <tr> <td><math>0.2 &lt; D \leq 0.5</math></td> <td>3</td> </tr> <tr> <td><math>0.5 &lt; D</math></td> <td>0</td> </tr> </table>	Zone Dimension	Acceptable Number	Class Of Defects	Acceptable Level	$D \leq 0.2$	Disregard	Minor	2.5	$0.2 < D \leq 0.5$	3	$0.5 < D$	0														
Zone Dimension	Acceptable Number	Class Of Defects	Acceptable Level																									
$D \leq 0.2$	Disregard	Minor	2.5																									
$0.2 < D \leq 0.5$	3																											
$0.5 < D$	0																											
		<p>Total defects shall not excess 3/module. Defect that is located at outside of AA and doesn't affect function is ignored. Bobble is sawn only under reflection light is disregarded.</p>																										
4	Displaying Pattern	<p>1. Incomplete or broken line is not allowed. 2. Pinholes</p> <table border="1"> <thead> <tr> <th>Dimension <math>\Phi</math>(mm)</th> <th>Criteria</th> <th>Class Of Defects</th> <th>Acceptable Level</th> </tr> </thead> <tbody> <tr> <td><math>\Phi &lt; 0.1</math></td> <td>Disregard</td> <td rowspan="4">Minor</td> <td rowspan="4">2.5</td> </tr> <tr> <td><math>0.1 &lt; \Phi \leq 0.2</math></td> <td>2</td> </tr> <tr> <td><math>0.2 &lt; \Phi \leq 0.25</math></td> <td>1</td> </tr> <tr> <td><math>0.25 &lt; \Phi</math></td> <td>0</td> </tr> </tbody> </table>  <p style="text-align: center;"><math>\phi = (X+Y)/2</math></p> <p>3. Deformation</p> <table border="1"> <thead> <tr> <th>Dimension <math>\Phi</math>(mm)</th> <th>Criteria</th> <th>Class Of Defects</th> <th>Acceptable Level</th> </tr> </thead> <tbody> <tr> <td><math>\Phi &lt; 0.15</math></td> <td>Disregard</td> <td rowspan="3">Minor</td> <td rowspan="3">2.5</td> </tr> <tr> <td><math>\Phi \leq 0.25</math> and <math>X \leq 1/2D</math></td> <td>3</td> </tr> <tr> <td><math>\Phi &gt; 0.25</math> and <math>X &gt; 1/2D</math></td> <td>0</td> </tr> </tbody> </table>  <p style="text-align: center;"><math>D</math> : 间距</p> <p style="text-align: center;"><math>\phi = (X+Y)/2</math></p>	Dimension $\Phi$ (mm)	Criteria	Class Of Defects	Acceptable Level	$\Phi < 0.1$	Disregard	Minor	2.5	$0.1 < \Phi \leq 0.2$	2	$0.2 < \Phi \leq 0.25$	1	$0.25 < \Phi$	0	Dimension $\Phi$ (mm)	Criteria	Class Of Defects	Acceptable Level	$\Phi < 0.15$	Disregard	Minor	2.5	$\Phi \leq 0.25$ and $X \leq 1/2D$	3	$\Phi > 0.25$ and $X > 1/2D$	0
Dimension $\Phi$ (mm)	Criteria	Class Of Defects	Acceptable Level																									
$\Phi < 0.1$	Disregard	Minor	2.5																									
$0.1 < \Phi \leq 0.2$	2																											
$0.2 < \Phi \leq 0.25$	1																											
$0.25 < \Phi$	0																											
Dimension $\Phi$ (mm)	Criteria	Class Of Defects	Acceptable Level																									
$\Phi < 0.15$	Disregard	Minor	2.5																									
$\Phi \leq 0.25$ and $X \leq 1/2D$	3																											
$\Phi > 0.25$ and $X > 1/2D$	0																											

Other Inspection standard reference Bolymin standard.

## 11. Reliability

### ■ Content of Reliability Test

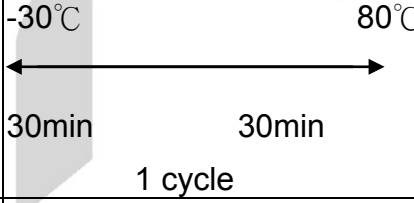
Environmental Test				
No	Test Item	Content of Test	Test Condition	Applicable Standard
1	High Temperature storage	Endurance test applying the high storage temperature for a long time.	80°C 96 hrs	—
2	Low Temperature storage	Endurance test applying the high storage temperature for a long time.	-30°C 96 hrs	—
3	High Temperature Operation	Endurance test applying the electric stress (Voltage & Current) and the thermal stress to the element for a long time.	70°C 96 hrs	—
4	Low Temperature Operation	Endurance test applying the electric stress under low temperature for a long time.	-20°C 96 hrs	—
5	Humidity Test	Endurance test applying the high humidity storage for a long time.	40°C, 90%RH 96hrs	—
6	Temperature cycle (Non-operation)	Endurance test applying the low and high temperature cycle. 	-30°C/80°C 10 cycles	—
7	Vibration test	Endurance test applying the vibration during transportation and using.	Total Fixed Amplitude: 1.5mm Vibration Frequency : 10~55Hz One cycle 60 seconds to 3 direction of X,Y,Z for each 15minutes	—

※Assess after placing at normal temperature and humidity for 4 hour ◦ No abnormalities in functions and appearance ◦

## 12. Appendix (Drawing , ST7548I controller data)

### 12.1 Drawing

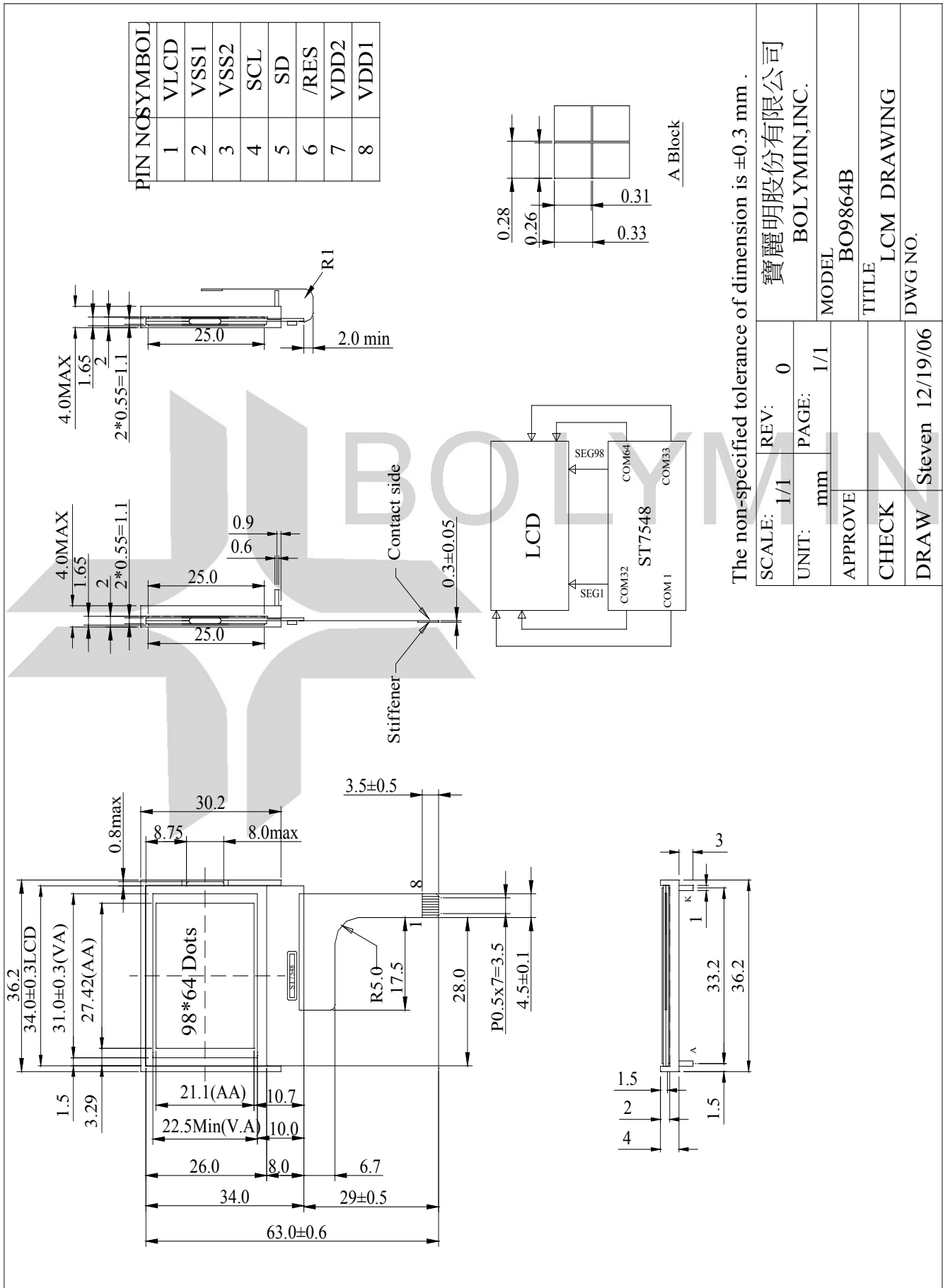

The non-specified tolerance of dimension is  $\pm 0.3 \text{ mm}$ .

SCALE:	REV:	0
UNIT:	PAGE:	1/1
APPROVE	MODEL	BO9864B
CHECK	TITLE	LCM DRAWING
DRAW	DWG NO.	Steven 12/19/06

寶麗明股份有限公司  
BOLYMIN, INC.

MODEL  
BO9864B

TITLE  
LCM DRAWING

DWG NO.  
Steven 12/19/06



## 12.2 ST7548i controller data

### 12.2.1. Instruction table

INSTRUCTION	A0	WR (R/W)	COMMAND BYTE								DESCRIPTION
			D7	D6	D5	D4	D3	D2	D1	D0	
H=0 or 1											
NOP	0	0	0	0	0	0	0	0	0	0	No operation
Reserved	0	0	0	0	0	0	0	0	0	1	Do not use
Function set	0	0	0	0	1	MX	MY	PD	V	H	Power-down; entry mode;
Read status byte	0	1	PD	0	0	D	E	MX	MY	DO	Read status byte
Write data	1	0	D <sub>7</sub>	D <sub>6</sub>	D <sub>5</sub>	D <sub>4</sub>	D <sub>3</sub>	D <sub>2</sub>	D <sub>1</sub>	D <sub>0</sub>	Write data to RAM

INSTRUCTION	A0	WR (R/W)	COMMAND BYTE								DESCRIPTION
			D7	D6	D5	D4	D3	D2	D1	D0	
H=0											
Reserved	0	0	0	0	0	0	0	0	1	X	Do not use
Set V0 range	0	0	0	0	0	0	0	1	0	PRS	V0 range L/H select
Display control	0	0	0	0	0	0	1	D	0	E	Sets display configuration
Reserved	0	0	0	0	0	1	0	0	X	X	Do not use
Set Y address of RAM	0	0	0	1	0	0	Y <sub>3</sub>	Y <sub>2</sub>	Y <sub>1</sub>	Y <sub>0</sub>	Sets Y address of RAM 0 ≤ Y ≤ 9
Set X address of RAM	0	0	1	X <sub>6</sub>	X <sub>5</sub>	X <sub>4</sub>	X <sub>3</sub>	X <sub>2</sub>	X <sub>1</sub>	X <sub>0</sub>	Sets X address of RAM 0 ≤ X ≤ 101
H=1											
Reserved	0	0	0	0	0	0	0	0	1	X	Do not use
Display configuration	0	0	0	0	0	0	1	DO	X	X	Set data order
Bias system	0	0	0	0	0	1	0	BS <sub>2</sub>	BS <sub>1</sub>	BS <sub>0</sub>	Sets bias system (BS <sub>x</sub> )
Reserved	0	0	0	1	X	X	X	X	X	X	Do not use(reserved for test)
Set V0 voltage (Set V <sub>OP</sub> )	0	0	1	V <sub>OP6</sub>	V <sub>OP5</sub>	V <sub>OP4</sub>	V <sub>OP3</sub>	V <sub>OP2</sub>	V <sub>OP1</sub>	V <sub>OP0</sub>	Write V0 (V <sub>OP</sub> ) voltage to register

### 12.2.2 . Timing characteristics Reset Timing

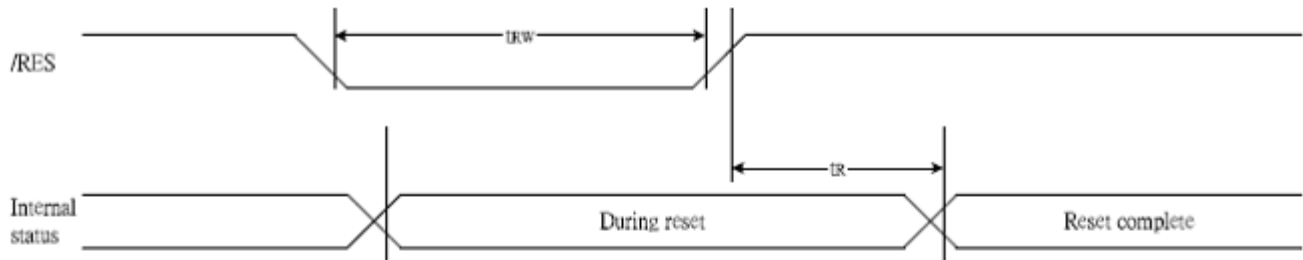

(VDD = 3.3V , Ta = -40 to 85°C )

Item	Signal	Symbol	Condition	Rating			Units
				Min.	Typ.	Max.	
Reset time		tR		—	—	1	us
Reset "L" pulse width	RESB	tRW		1	—	—	us

(VDD = 2.7V , Ta = -40 to 85°C )

Item	Signal	Symbol	Condition	Rating			Units
				Min.	Typ.	Max.	
Reset time		tR		—	—	2.0	us
Reset "L" pulse width	RESB	tRW		2.0	—	—	us

(VDD = 1.8V , Ta = -40 to 85°C )

Item	Signal	Symbol	Condition	Rating			Units
				Min.	Typ.	Max.	
Reset time		tR		—	—	3.0	us
Reset "L" pulse width	RESB	tRW		3.0	—	—	us



### Serial Interface(I2C interface)

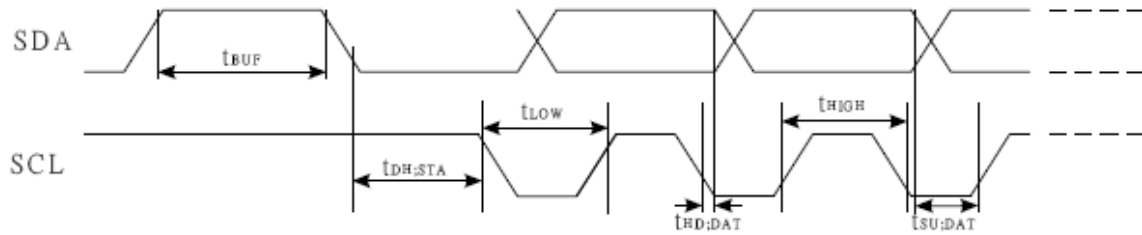

(V<sub>DD</sub>=3.3V, T<sub>a</sub>=25°C)

Item	Signal	Symbol	Condition	Rating		Units
				Min.	Max.	
SCL clock frequency	SCL	F <sub>SCLK</sub>		-	400	kHZ
SCL clock low period	SCL	T <sub>LOW</sub>		1.3	-	us
SCL clock high period	SCL	T <sub>HIGH</sub>		0.6	-	us
Data set-up time	SI	T <sub>SU</sub> ;Data		100	-	ns
Data hold time	SI	T <sub>HD</sub> ;Data		0	0.9	us
SCL,SDA rise time	SCL	T <sub>R</sub>		20+0.1Cb	300	ns
SCL,SDA fall time	SCL	T <sub>F</sub>		20+0.1Cb	300	ns
Capacitive load represented by each bus line		C <sub>b</sub>		-	400	pF
Setup time for a repeated START condition	SI	T <sub>SU</sub> ;SUA		0.6	-	us
Start condition hold time	SI	T <sub>HD</sub> ;STA		0.6	-	us
Setup time for STOP condition		T <sub>SU</sub> ;STO		0.6	-	us
Tolerable spike width on bus		T <sub>SW</sub>		-	50	ns
BUS free time between a STOP and START condition	SCL	T <sub>BUF</sub>		1.3		us



## I2C Interface Protocol

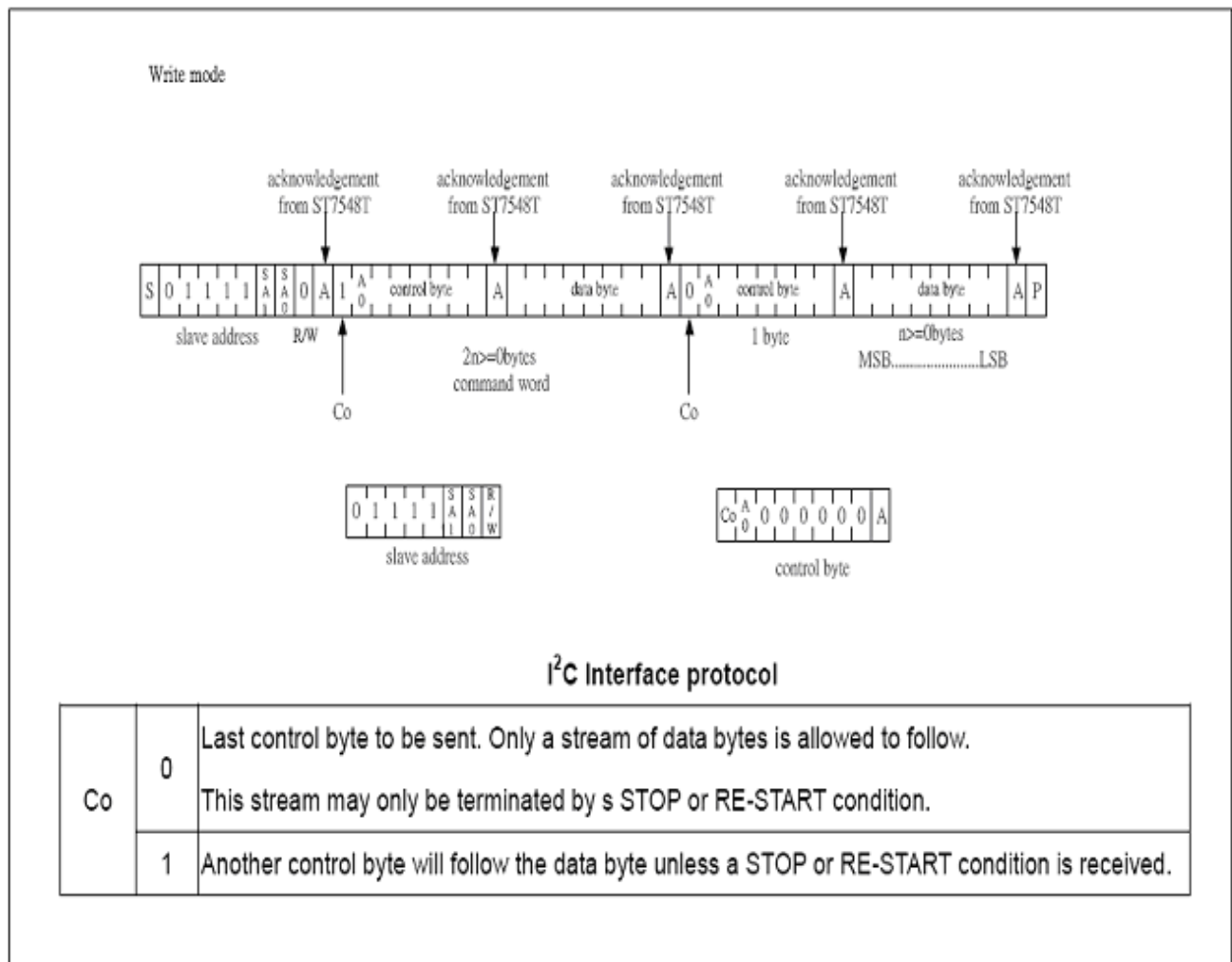
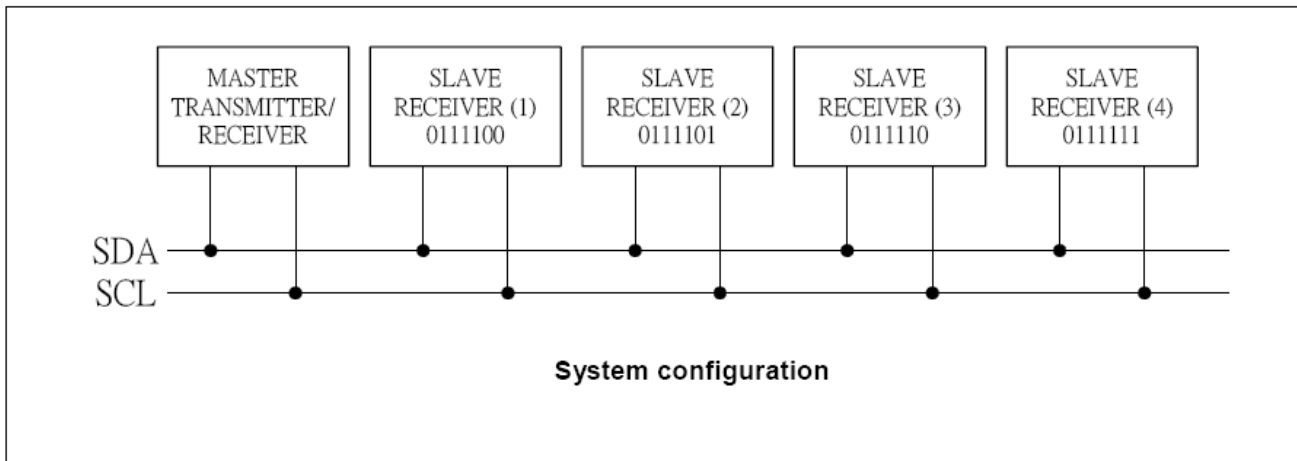

## 12.2.3 Instruction Description

H="0" or "1"

### Function Set

A0	WR(R/W)	D7	D6	D5	D4	D3	D2	D1	D0
0	0	0	0	1	MX	MY	PD	V	H

Flag	Description
MX	SEG bi-direction selection MY=0:normal direction (SEG0->SEG101) MY=1:reverse direction (SEG101->SEG0)
MY	COM bi-direction selection See Pad Center Coordinates at page 3~10 when using this register
PD	All LCD outputs at VSS (display off), bias generator and V0 generator off, VOUT can be disconnected, oscillator off (external clock possible), RAM contents not cleared; RAM data can be written. PD=0:chip is active PD=1:chip is in power down mode
V	When V = 0, the horizontal addressing is selected. When V = 1, the vertical addressing is selected.
H	When H = 0 the commands 'display control', 'set Y address' and 'set X address' can be performed, when H = 1 the others can be executed. The commands 'write data' and 'function set' can be executed in both cases. H=0:use basic instruction set H=1:use extended instruction set

### Read status byte

Indicates the internal status of the ST7548T

A0	WR(R/W)	D7	D6	D5	D4	D3	D2	D1	D0
0	1	PD	0	0	D	E	MX	MY	DO

Flag	Description
PD	PD=0:chip is active PD=1:chip is in power down mode
D,E	D E The bits D and E select the display mode.
	0 0 Display blank
	0 1 All display segments on
	1 0 Normal mode
	1 1 Inverse video mode
DO	DO=0:MSB is on top DO=1:LSB is on top

### Write data

8-bit data of Display Data from the microprocessor can be written to the RAM location specified by the column address and page address. The column address is increased by 1 automatically so that the microprocessor can continuously write data to the addressed page. During auto-increment, the column address wraps to 0 after the last column is written.

A0	WR(R/W)	D7	D6	D5	D4	D3	D2	D1	D0
1	0	Write data							

H= "0"

### Set V0 range

V0 range L/H select

A0	WR(R/W)	D7	D6	D5	D4	D3	D2	D1	D0
0	0	0	0	0	0	0	1	0	PRS

PRS=0: V0 programming range LOW

PRS=1: V0 programming range HIGH

### Display Control

This bits D and E selects the display mode.

A0	WR(R/W)	D7	D6	D5	D4	D3	D2	D1	D0
0	0	0	0	0	0	1	D	0	E

Flag	Description		
D,E	D	E	The bits D and E select the display mode.
	0	0	Display blank
	1	0	Normal display
	0	1	All display segments on
	1	1	Inverse video mode

### Set Y address of RAM

Y [3:0] defines the Y address vector address of the display RAM.

A0	WR(R/W)	D7	D6	D5	D4	D3	D2	D1	D0
0	0	0	1	0	0	Y <sub>3</sub>	Y <sub>2</sub>	Y <sub>1</sub>	Y <sub>0</sub>

Y <sub>3</sub>	Y <sub>2</sub>	Y <sub>1</sub>	Y <sub>0</sub>	CONTENT	ALLOWED X-RANGE
0	0	0	0	Page0 (display RAM)	0 to 101
0	0	0	1	Page1 (display RAM)	0 to 101
0	0	1	0	Page2 (display RAM)	0 to 101
0	0	1	1	Page3 (display RAM)	0 to 101
0	1	0	0	Page4 (display RAM)	0 to 101
0	1	0	1	Page5 (display RAM)	0 to 101
0	1	1	0	Page6 (display RAM)	0 to 101
0	1	1	1	Page7 (display RAM)	0 to 101
1	0	0	0	Page8 (display RAM)	0 to 101
1	0	0	1	Page9 (display RAM)	0 to 101

### Set X address of RAM

The X address points to the columns. The range of X is 0...101.

A0	WR(R/W)	D7	D6	D5	D4	D3	D2	D1	D0
0	0	1	X <sub>6</sub>	X <sub>5</sub>	X <sub>4</sub>	X <sub>3</sub>	X <sub>2</sub>	X <sub>1</sub>	X <sub>0</sub>

X <sub>6</sub>	X <sub>5</sub>	X <sub>4</sub>	X <sub>3</sub>	X <sub>2</sub>	X <sub>1</sub>	X <sub>0</sub>	Column address
0	0	0	0	0	0	0	0
0	0	0	0	0	0	1	1
0	0	0	0	0	1	0	2
0	0	0	0	0	1	1	3
:	:	:	:	:	:	:	:
1	1	0	0	0	1	0	98
1	1	0	0	0	1	1	99
1	1	0	0	1	0	0	100
1	1	0	0	1	0	1	101

H= "1"

### Display configuration

Top/bottom row mode set data order

A0	WR(R/W)	D7	D6	D5	D4	D3	D2	D1	D0
0	0	0	0	0	0	1	DO	X	X

Flag	Description
Do	Do=0:MSB is on top Do=1:LSB is on top

### System Bias

Select LCD bias ratio of the voltage required for driving the LCD.

A0	WR(R/W)	D7	D6	D5	D4	D3	D2	D1	D0
0	0	0	0	0	1	0	BS <sub>2</sub>	BS <sub>1</sub>	BS <sub>0</sub>

BS <sub>2</sub>	BS <sub>1</sub>	BS <sub>0</sub>	Bias	Recommend Duty
0	0	0	11	1:100
0	0	1	10	1:81
0	1	0	9	1:65/1:68
0	1	1	8	1:49
1	0	0	7	1/40:1/36
1	0	1	6	1/24
1	1	0	5	1:18/1:16
1	1	1	4	1:10/1:9/1:8

### Set V0 voltage (Set V<sub>OP</sub>)

A0	WR(R/W)	D7	D6	D5	D4	D3	D2	D1	D0
0	0	1	V <sub>OP6</sub>	V <sub>OP5</sub>	V <sub>OP4</sub>	V <sub>OP3</sub>	V <sub>OP2</sub>	V <sub>OP1</sub>	V <sub>OP0</sub>

The operation voltage V0 (V<sub>OP</sub>) can be set by software.

$$V0 = (a + V_{OP} \times b) \quad (1)$$

The maximum voltage that can be generated is depending on the VDD1 voltage and the display load current. Two overlapping V0 ranges are selectable via the command "Set V0 Range". For the LOW (PRS=0) range a=a1 and for the HIGH (PRS=1) range a=a2 with steps equal to "b" in both ranges. Note that the charge pump is turned off if V<sub>OP</sub> [6;0] and the bit PRS are all set to zero

Typical values for parameter for the HV-Generator programming

SYMBOL	VALUE	UNIT
a1	2.94(PRS=0)	V
a2	6.75(PRS=1)	V
b	0.03	V

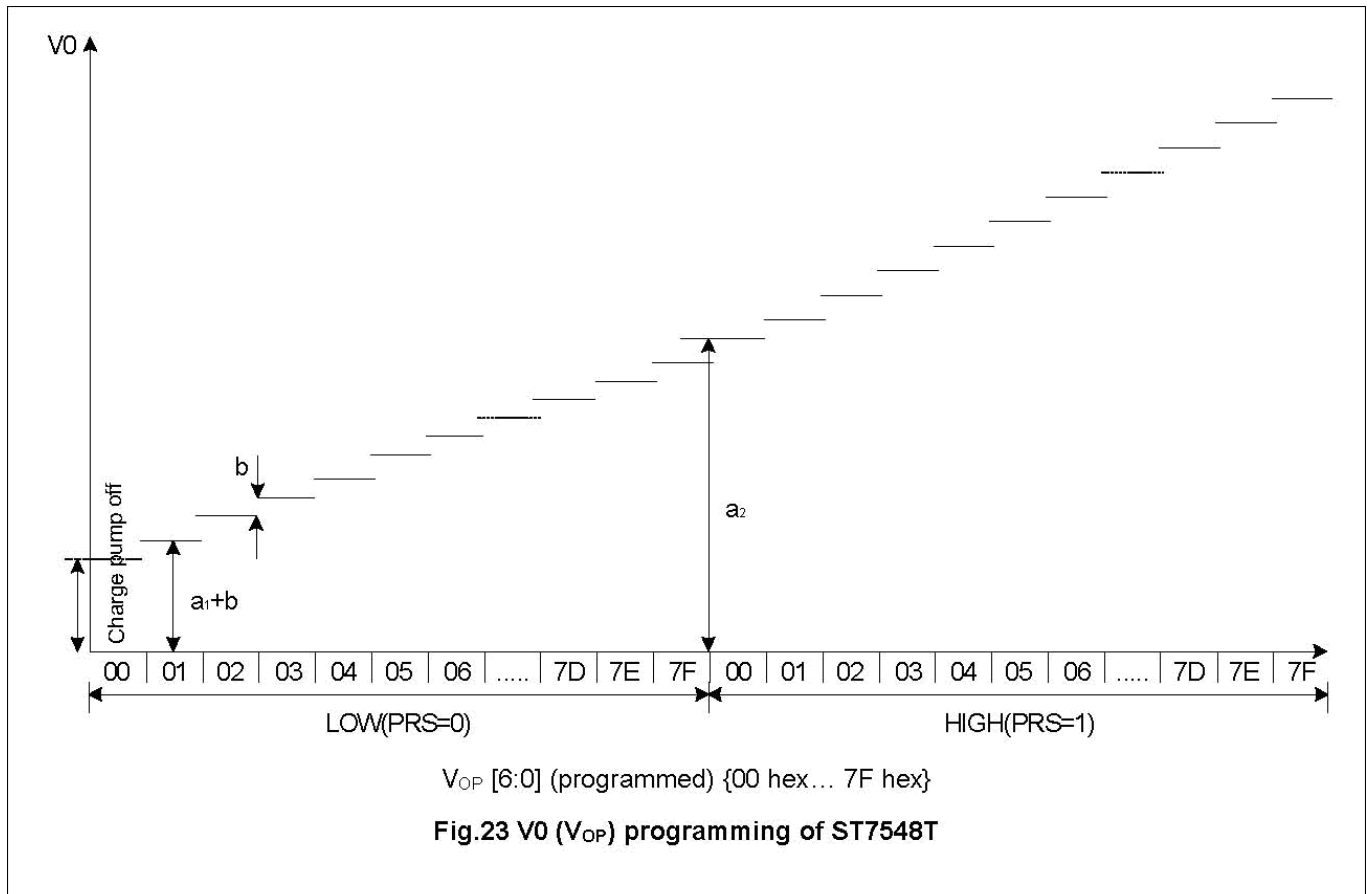



## 12.2.4 Command description

### Referential Instruction Setup Flow: Initializing with the built-in Power Supply Circuits

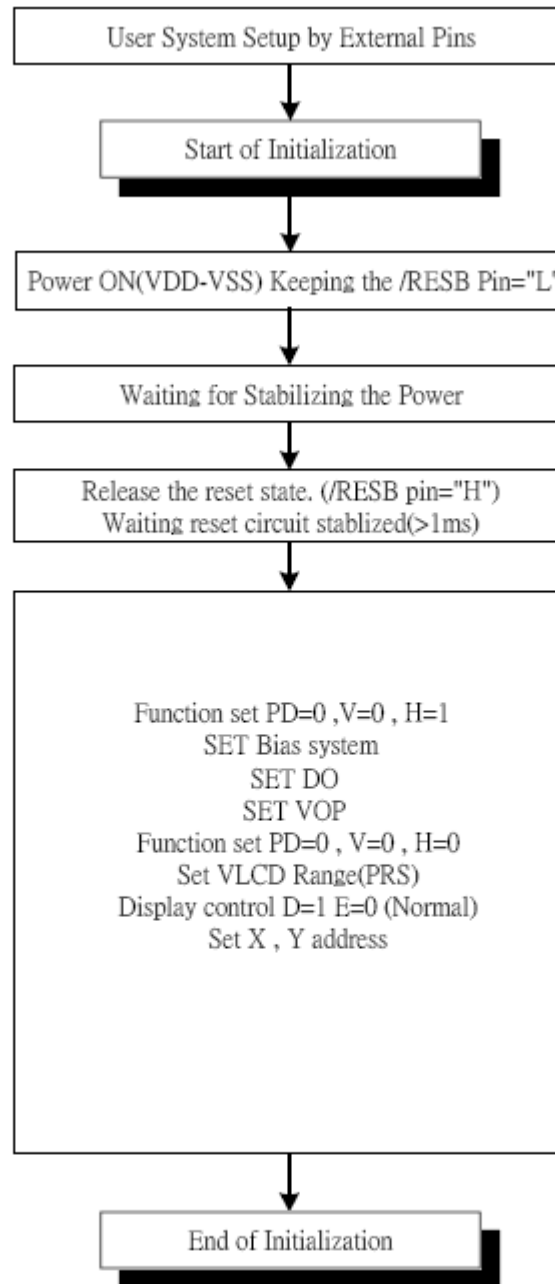

Initializing with the Built-in Power Supply Circuits

### 12.2.5 Internal DC/DC generator

